

NC Series Digital PID Controller Operation Manual

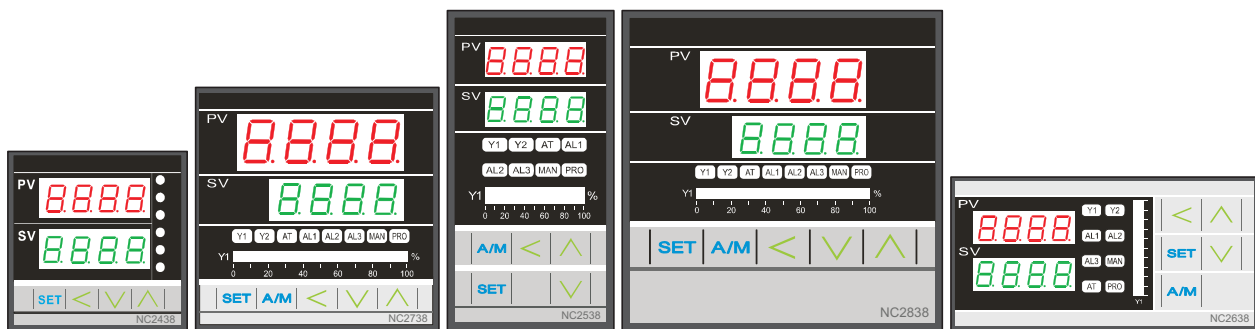

NC2438

48x48
(DIN 1/16)

NC2738

72X72
(DIN 3/16)

NC2538

48X96
(DIN 1/8)

NC2838

96X96
(DIN 1/4)

NC2638

96X48
(DIN 1/8)

CONTENT

1	Notice before start- up	Page 3
2	Specifications	Page 4
3	Terminal arrangement	
3.1	NC2438 Terminals	Page 6
3.2	NC2638 Terminals	Page 7
3.3	NC2738 Terminals	Page 8
3.4	NC2538 Terminals	Page 9
3.5	NC2838 Terminals	Page 10
4	External dimension and panel cutout	Page 11
5	Parts description.....	Page 12
6	Operations	
6.1	Power On	Page 13
6.2	Change the Set Value (SV)	Page 13
6.3	Change The Alarm Value.....	Page 13
6.4	Auto tuning (AT)	Page 14
6.5	Programmable RAMP / SOAK	Page 15
7	Operation levels	
7.1	Levels diagram	Page 16
7.2	Lock function	Page 16
8	Parameters	
8.1	Level 1 (User Level)	Page 17
8.2	Level 2 (PID Level)	
8.2.1	Level 2 parameters display / hiding condition.....	Page 18
8.2.2	Description of parameters.....	Page 19
8.3	Level 3 (Input Level)	Page 20
8.4	Level 4 (SET Level)	
8.4.1	How to hide parameters (Use SET1~SET7)	Page 22
8.4.2	Special functions (Use SET8 / SET9 / SET0).....	Page 23
8.4.3	Remote SV type selection.....	Page 24
8.4.4	Output mode selection (Use OUTY)	Page 24
8.5	Program Level	
8.5.1	Description of parameters	Page 25
8.5.2	Description of operation.....	Page 26
9	Input type table	Page 27
10	Alarm	
10.1	Alarm time.....	Page 29
10.2	SETA	Page 29
10.3	Alarm mode	Page 30

11	Heater Break Alarm(HBA)	Page 31
12	Error codes	Page 34
13	Modify input type: TC, RTD	Page 35
14	Modify input type: Linear Input (mA ,V)	
14.1	Hardware	Page 36
14.2	Calibration	Page 37
15	Modify output type: Relay, SSR, 4~20mA	Page 38
16	Modify output mode: OUT1/ALARM, OUT1/OUT2	Page 38
17	Applications	
17.1	RAMP & SOAK	Page 39
17.2	TTL Communication : SV output and RATE function.....	Page 40
17.3	1 \emptyset Phase angle control (By SCR module)	Page 41
17.4	1 \emptyset Phase angle control (By TRIAC)	Page 42
17.5	3 \emptyset Phase angle control (By DIODE/SCR module).....	Page 43
17.6	1 \emptyset Zero crossing control (By SCR Module)	Page 44
17.7	1 \emptyset Zero crossing control (By TRIAC)	Page 45
17.8	3 \emptyset Zero crossing control (By SCR module)	Page 46
17.9	3 \emptyset Zero crossing control (By TRIAC)	Page 47
17.10	3 wires proportional motor valve control	Page 48
17.11	Wiring diagram of PC Communication	Page 49

1. Notice before start-up

NC series controller has got the CE approvals as below:

LDV : D/N EN61010-1

EMC : EN 55 022 1994 /A1 : 1995/ A2 : 1997

EN 61 000-3-2 : 1995 / -3-3 : 1995

EN 61 000-4-2 : 1995 / -4-3 : 1996 / -4-5 : 1995 / -4-6

1996 / -4-8 : 1993 / -4-11 : 1996/ EN 50 204 : 1995

Please confirm the specification of controller is to totally with your requirement before using it, also read this manual in detail.

Danger

1. Danger! Electric Shock!

DON'T touch AC power wiring terminals when controller has been powered!

Keep the power off until all of the wirings are completed!

Warning

1. Please confirm the AC power wiring to controller is correct, otherwise it would be caused aggravated damage on controller. (NC2438 connecting with Pin 1 and 6, NC2538/NC2638/NC2738/NC2838 with Pin 1 and 2).

2. Be sure to use the rated power supply (AC85~265V or DC24V), otherwise it would be caused aggravated damage on controller.

3. Please confirm wires are connected with correct terminal (Input, Output).

4. Use M3 screw-compatible crimp-on terminals with an insulation sleeve, as shown below

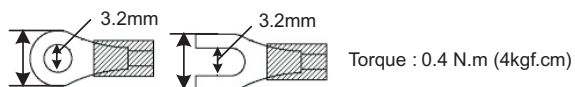

5. Avoid installing controller in following spaces:

I. A place where the ambient temperature may reach beyond the range from 0 to 50 °C

II. A place where the ambient humidity may reach beyond the range from 20 to 90% RH.

III. A place where the controller likely to come into contact with water, oil, chemicals, steam and vapor.

IV. A place where the controller is subject to interface with static electricity, magnetism and noise.

6. For thermocouple (TC) input, use shield compensating lead wire.

7. For RTD input, use shield wires which have low resistance and no resistance difference between the 3 wires.

1. Specifications

△ Standard spec.

Model	NC2438	NC2638	NC2738	NC2538	NC2838
Dimension	48X48mm	96X48mm	72X72mm	48X96mm	96X96mm
Supply voltage	AC 85~265V , DC 15~50V (Option)				
Frequency	50 / 60 HZ				
Power consumption	approx 3VA	approx 4VA	approx 3VA	approx 4VA	approx 4VA
Input	Accuracy	0.2 % FS \pm 1digit			
	Sample time	250ms			
	TC	K , J , R , S , B , E , N , T , W5Re/W26Re , PLII , U , L			
	RTD	PT100,JPT100,JPT50			
	mA DC	4~20mA , 0~20mA			
	mV / V DC	0~1V, 0~5V, 0~10V, 1~5V, 2~10VDC -10~10mV, 0~10mV, 0~20mV, 0~50mV, 10~50mV			
	Decimal point position	0000 , 000.0 , 00.00 , 0.000 Available for linear input (mA / mV / V)			
Output 1	Relay	SPST type	SPDT type	SPST type	SPDT type
		3A , 220V , electrical life:100,000 times or more (under rated load)			
	Voltage pulse	For SSR drive. ON : 24V , OFF : 0V , max load current : 20mA			
	mA DC	4~20mA, 0~20mA. Maximum load resistance:560 Ω			
	Voltage DC	0~5V , 0~10V , 1~5V , 2~10V . Max load current:20mA			
Alarm 1	3A , 220V , electrical life:100,000 times or more (under rated load)				
Control algorithm	PID , PI , PD , P , ON / OFF(P=0) , FUZZY				
PID range	P: 0.0 ~ 200.0 % , I: 0~3600s , D: 0~900s				
Isolation	Output terminals(control output , alarm , transmission) and input terminals are isolated separately				
Isolated resistance	10M Ω or more between input and case (ground) at DC 500 V 10M Ω or more between output and case (ground) at DC 500 V				
Dielectric strength	1000V AC for 1 minute between input terminal and case (ground) 1500V AC for 1 minute between output terminal and case (ground)				
Operating temperature	0~50 $^{\circ}$ C				
Humidity range	20~90%RH				
Weight	150g	225g	225g	225g	300g
Display Height	PV:7mm SV:7mm	PV:7mm SV:7mm	PV:14mm SV:10mm	PV:7mm SV:7mm	PV:14mm SV:10mm

*** Optional Spec.**

Model	NC2438	NC2638	NC2738	NC2538	NC2838
Output 2	For heating and cooling control use. Relay , SSR , 4~20mA , 0~20mA , 0~5V , 0~10V , 1~5V , 2~10V				
Alarm 2	SPST type	SPDT type	SPST type	SPDT type	SPDT type
	3A , 220V , electrical life:100,000 times or more (under rated load)				
Alarm 3	Not available	Available	Available	Available	Available
		SPST type	SPST type	SPST type	SPST type
	3A , 220V , electrical life:100,000 times or more (under rated load)				
Heater Break Alarm (HBA)	Display range of heater current : 0.0~99.9A , Accuracy : 1%FS				
	Included CT : SC-80-T (5.8mm dia , 0.0~80.0A) or SC-100-T (12mm dia , 0.0~99.9A)				
	Alarm relay : AL1				
Transmission	Available for PV or SV transmission				
	4~20mA , 0~20mA , 0~1V , 0~5V , 0~10V , 1~5V , 2~10V				
Remote SV	4~20mA , 0~20mA , 0~1V , 0~5V , 0~10V , 1~5V , 2~10V				
Communication	Protocol : MODBUS RTU , MODBUS ASCII , TAIE				
	RS232 , RS485 , TTL				
	Baud rate: 2400 , 4800 , 9600 , 19200 , 38400 bps. Data bits : 8 , Stop bit : 1 or 2bit , Odd or Even parity.				
Water/Dust proof	IP65				

*** Special control output (OUT1)**

Model	NC2438	NC2638	NC2738	NC2538	NC2838
1φ zero crossing control(1φSSR)	Available	Not available	Available	Not available	Available
3φ zero crossing control(3φSSR)	Not available				Available
Motor valve control	Available				
1φ phase angle control(1φSCR)	Not available	Available			
3φ phase angle control(3φSCR)	Not available				Available

*** Programmable RAMP/SOAK**

Model	NC2438P	NC2638P	NC2738P	NC2538P	NC2838P
Programmable RAMP/SOAK	2 patterns with 8 segments each. The 2 patterns can be linked together as 16 segments use.				

3. Terminal arrangement

3.1 NC2438 Terminals (48mm x 48mm , DIN 1/16)

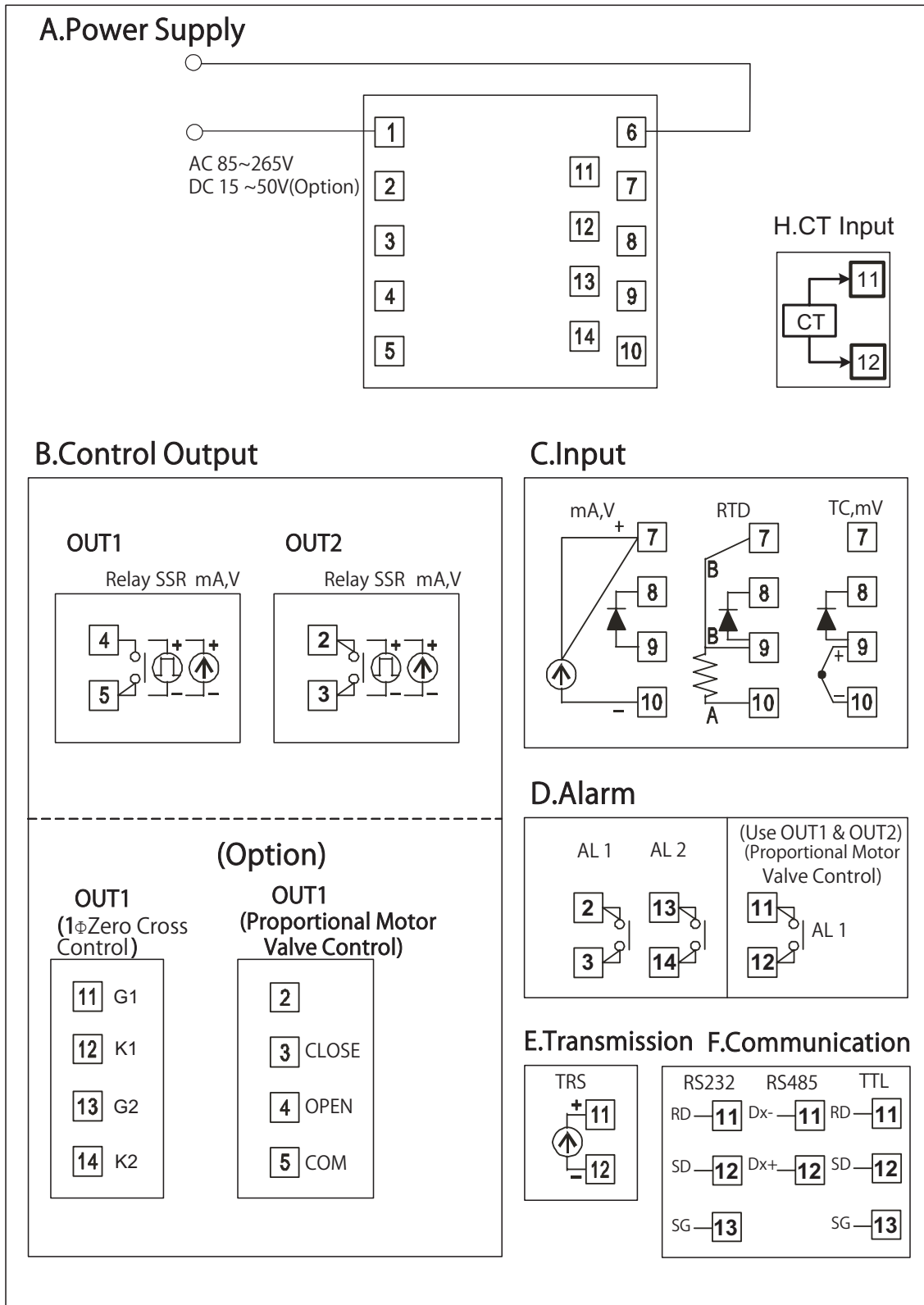

3.2 NC2638 Terminals (96mm x 48mm , DIN 1/8)

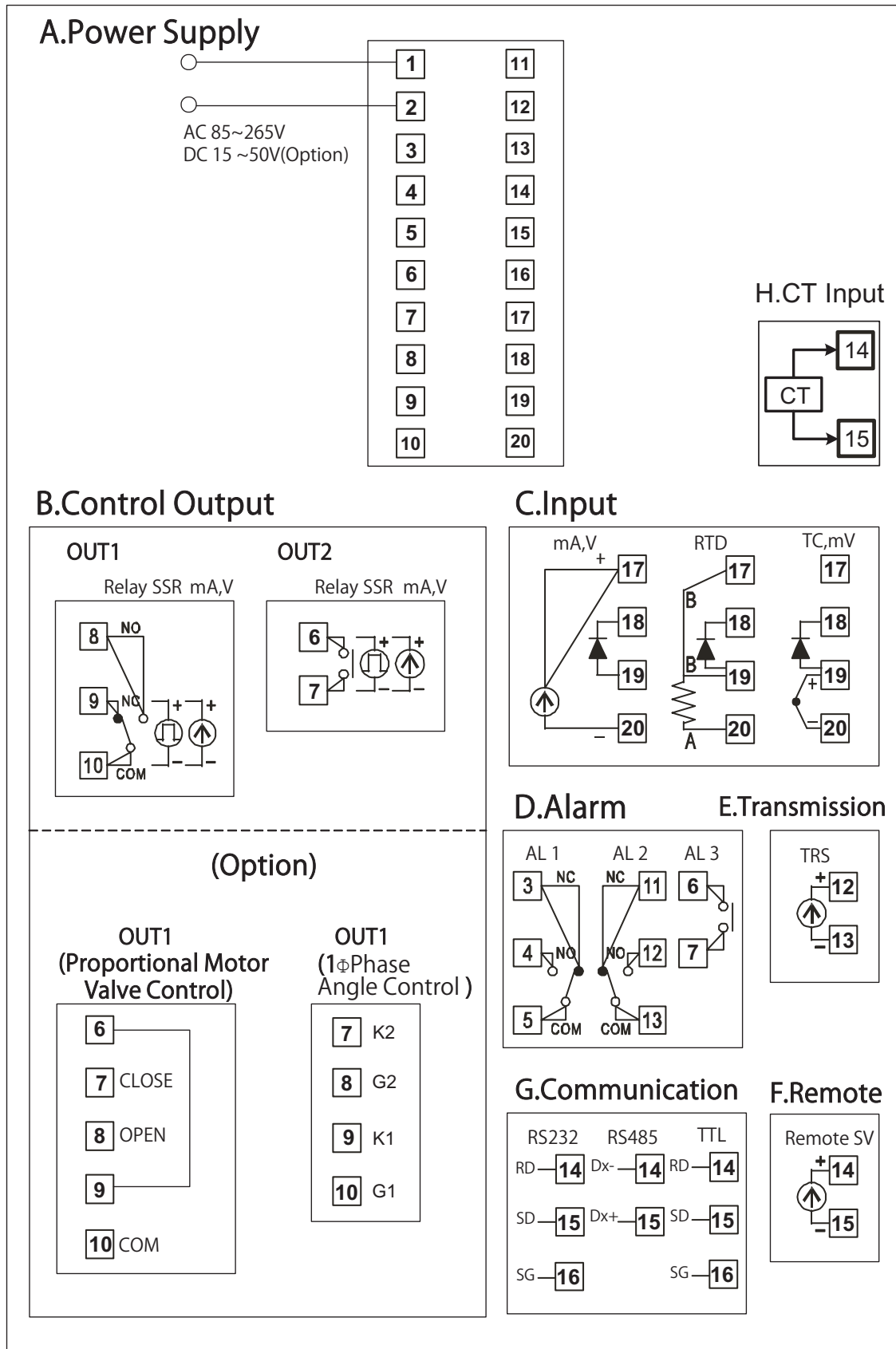

3.3 NC2738 Terminals (72mm x 72mm)

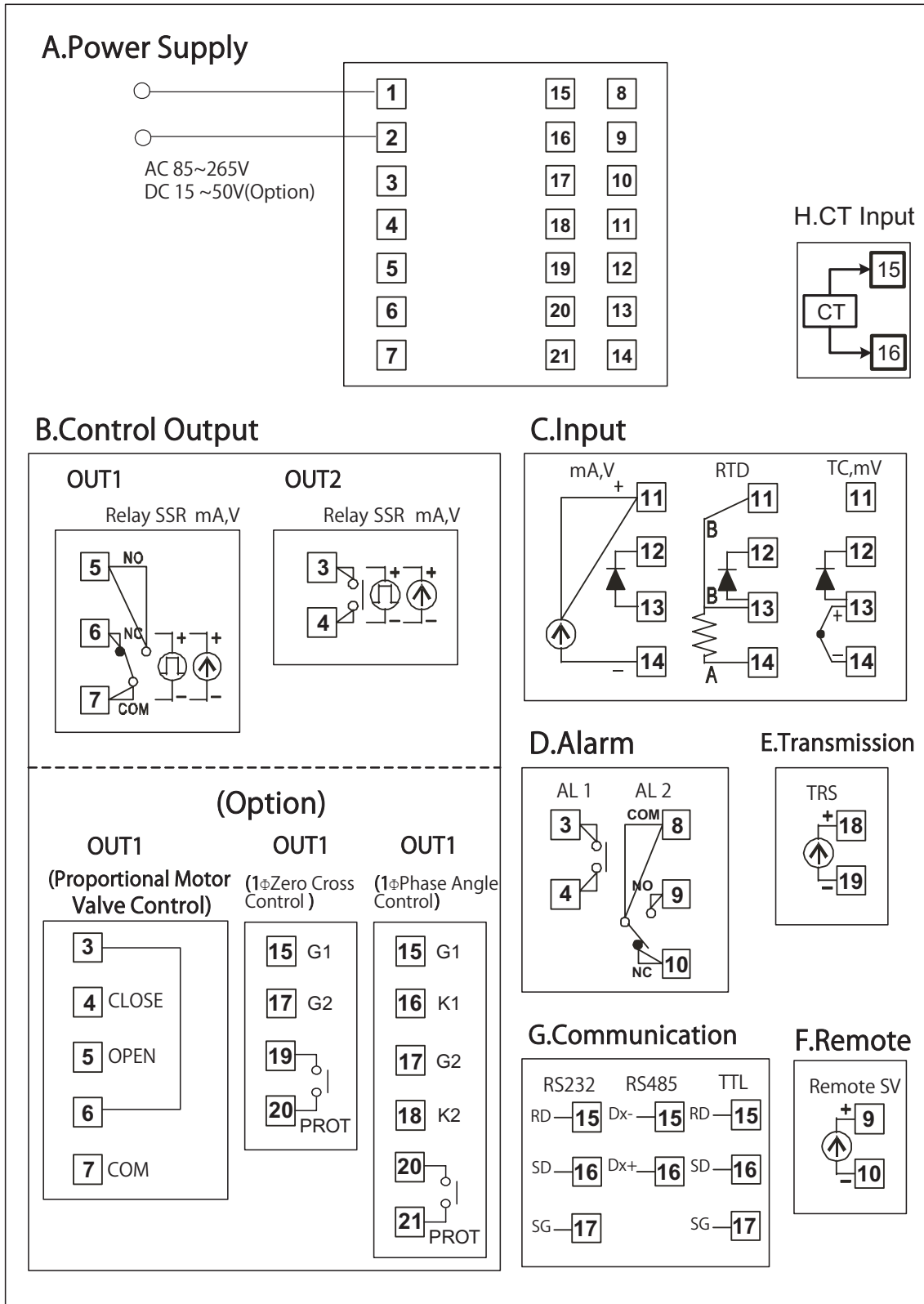

3.4 NC2538 Terminals (48mm x 96mm , DIN 1/8)

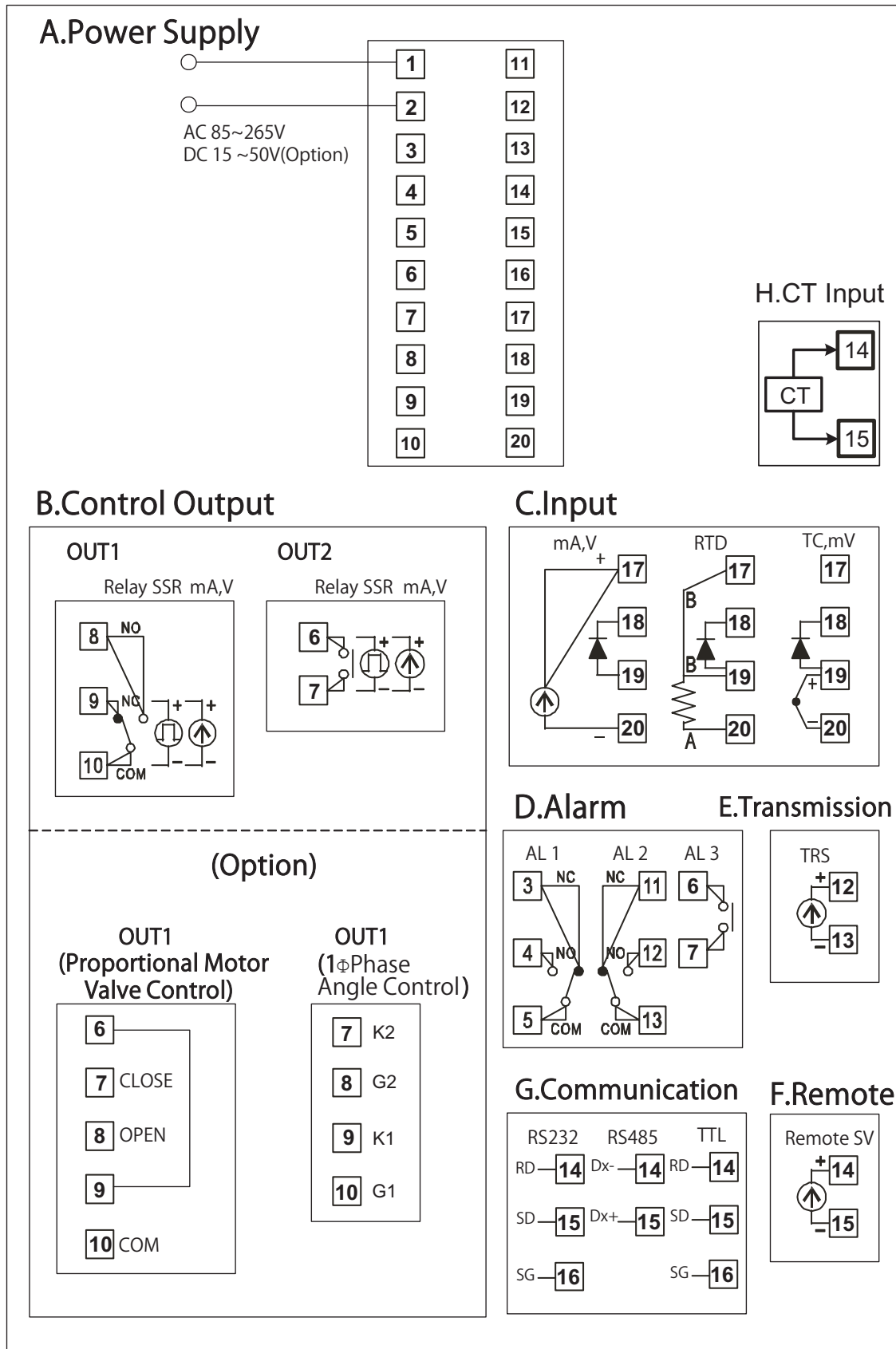

3.5 NC2838 Terminals (96mm x 96mm , DIN 1/4)

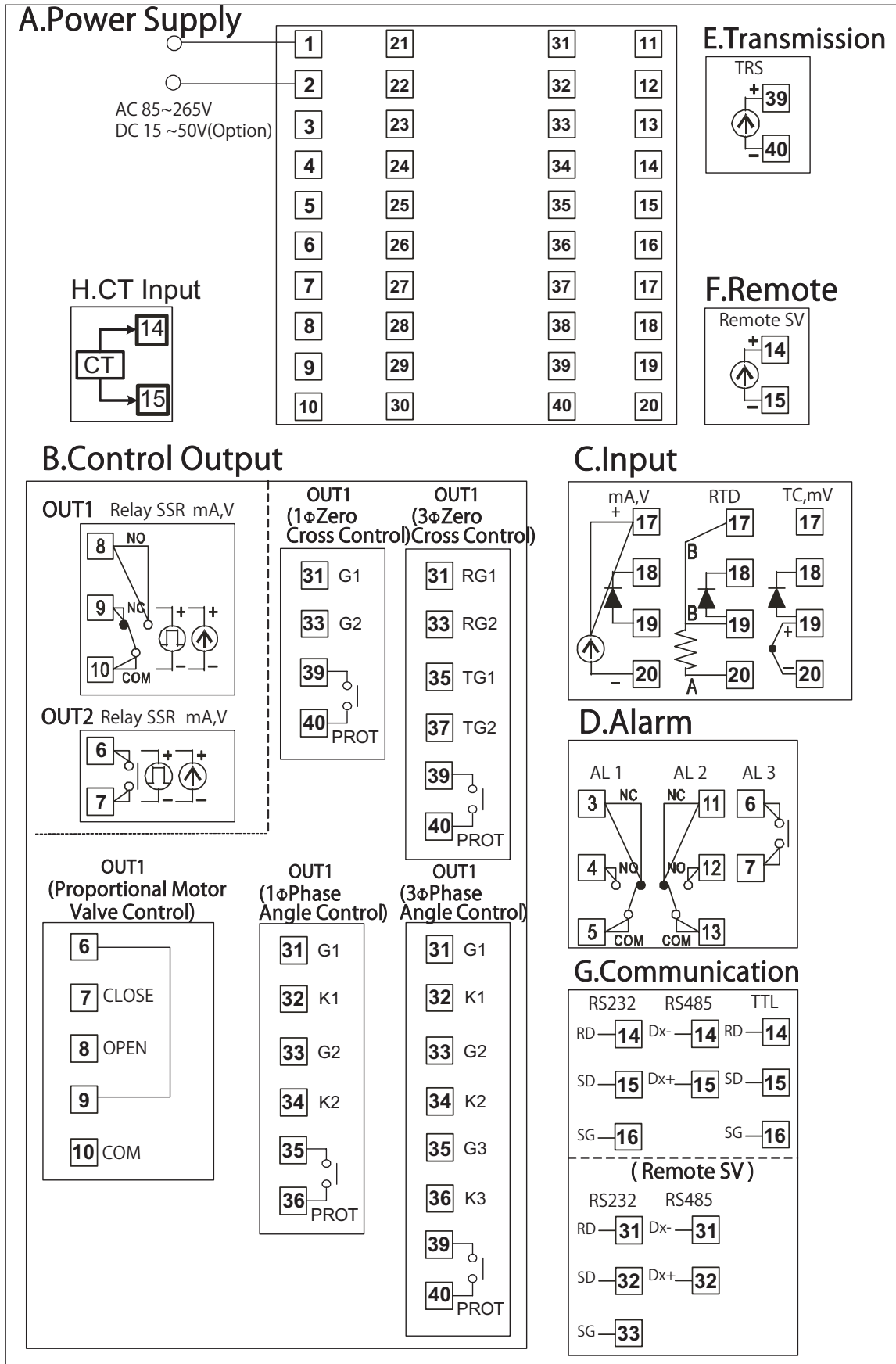

4. External dimension and panel cutout Unit : mm

NC2438

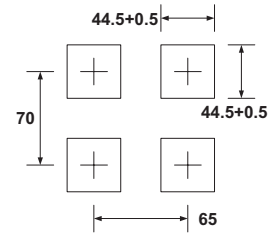
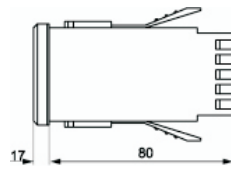
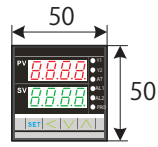

NC2638

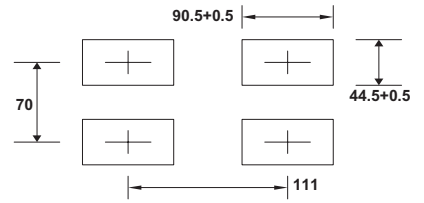
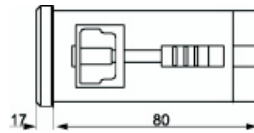
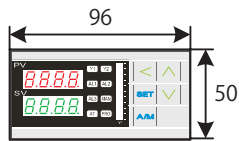

NC2738

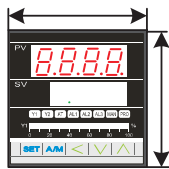

5. Parts description

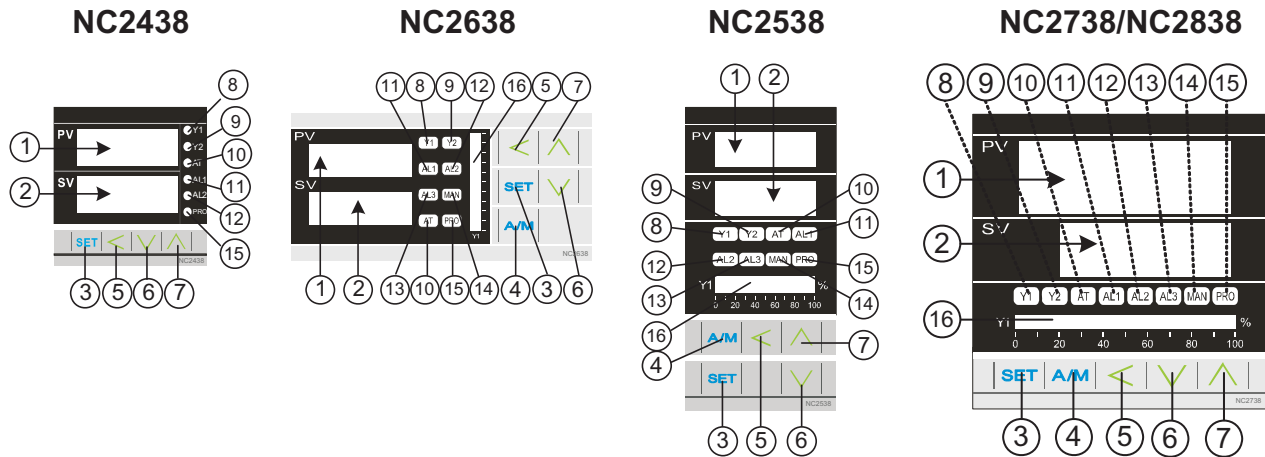

SYMBOL	NAME		FUNCTION
PV	①	Measured value (PV) display	Displays PV or various parameter symbols (Red)
SV	②	Set value (SV) display	Displays SV or various parameter set values (Green)
SET	③	Set key	Used for parameter calling up and set value registration
A/M	④	Auto/Manual key	Switches between Auto(PID) output mode and Manual output mode.
<	⑤	Shift key	Shift digits when settings are changed
∇	⑥	Down key *Program hold	Decrease numbers (-1000,-100,-10,-1) * Program hold (Programmable controller)
∧	⑦	Up key *Program run	Decrease numbers (+1000,+100,+10,+1) * Program run (Programmable controller)
OUT1	⑧	OUT1 lamp	Lights when OUT1 is activated (Green)
OUT2	⑨	OUT2 lamp	Lights when OUT2 is activated (Green)
AT	⑩	Auto tuning lamp	Lights when Auto tuning is activated (Orange)
AL1	⑪	Alarm 1 lamp	Lights when Alarm 1 is activated (Red)
AL2	⑫	Alarm 2 lamp	Lights when Alarm 2 is activated (Red)
AL3	⑬	Alarm 3 lamp	Lights when Alarm 3 is activated (Red)
MAN	⑭	Manual output lamp	Lights when manual output is activated (Orange)
PRO	⑮	*Program running lamp	*Flashes when program is running (Programmable controller)
OUT1%	⑯	OUT% bar-graph display	Output% is displayed on 10-dot LED.

6. Operations

6.1 Power On

Controller will display as below

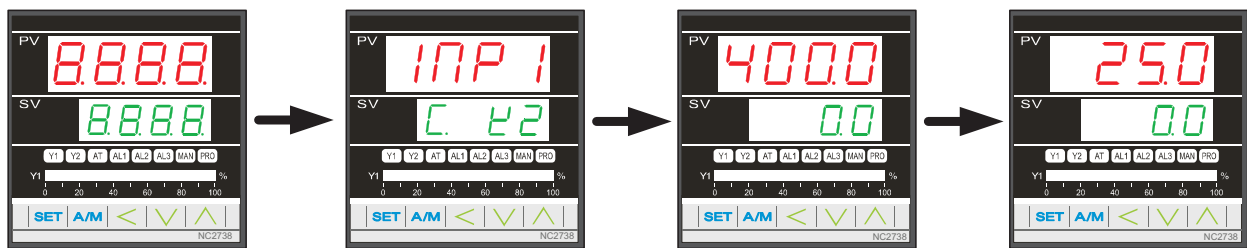

All LED and 7 segment displays will be lighted

Display input type (K2)

Display range (0.0~400.0)

Ready for use

6.2 Change the Set Value (SV)

Change SV from 0.0 to 100.0

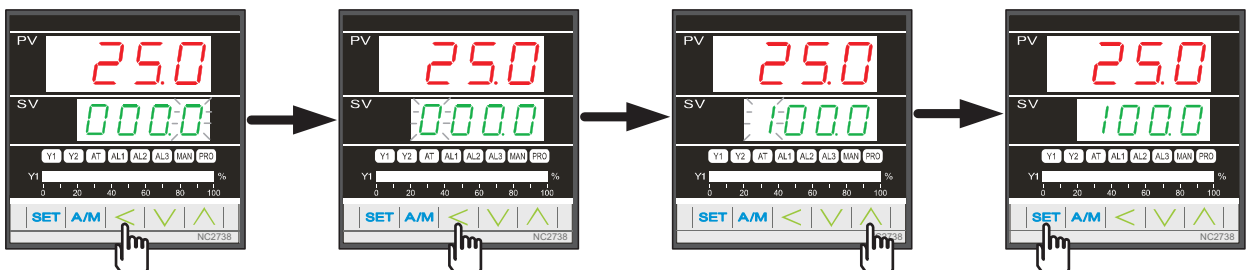

Press **<** key. The SV number started to flash. The flashing digit indicates which digit can be set.

Press **<** key to select the hundreds digit.

Press **>** key to change the number to 1

Press **SET** key to store the new set value.

6.3 Change the Alarm Value

Change AL1 value to "5.0" (AL1 active, if PV exceeds SV over 5.0)

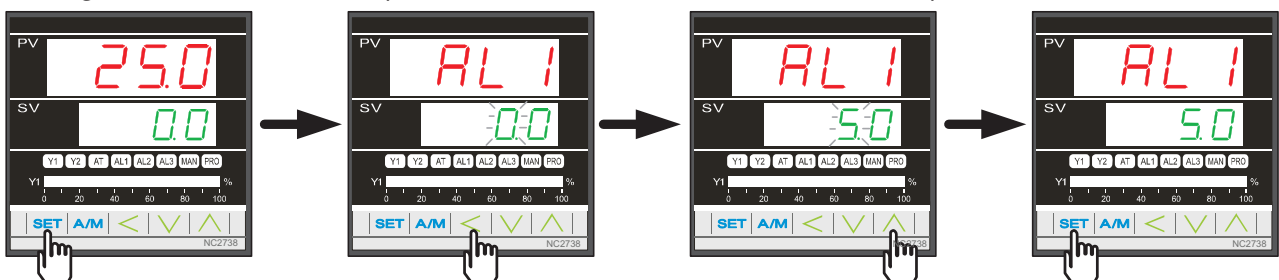

Press **SET** key to display parameter AL1

Press **<** key to change AL1 value

Press **>** key increase AL1 value

Press **SET** key store the new value of AL1

* The are total 16 alarm mode types, please referred with "alarm mode" in page 30

* To change alarm mode, press **SET** + **<** key 5 seconds to enter Level 3 (Input Level) and then change ALD1/ALD2/ALD3 value.

6.4 Autotuning (AT)

Use AT function to automatically calculate and set the optimize PID value for your system.

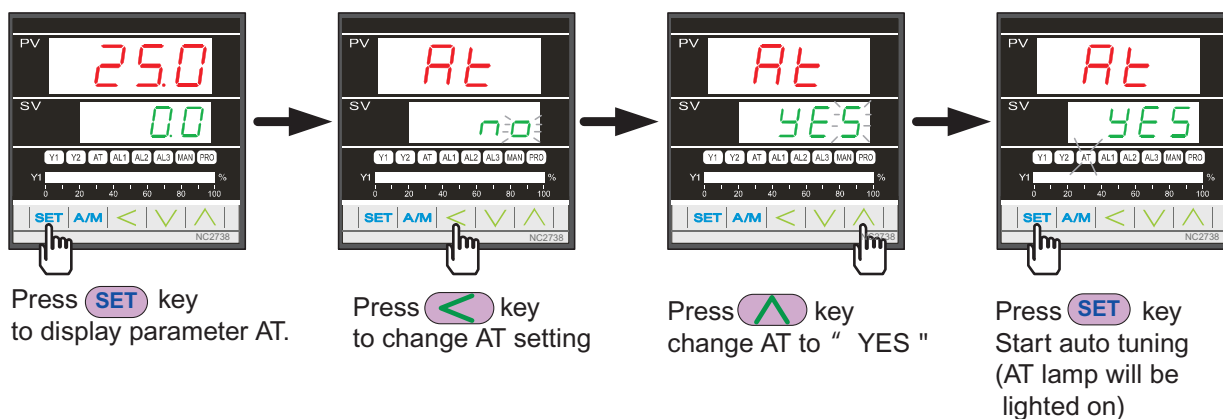

Autotuning
ATVL=0

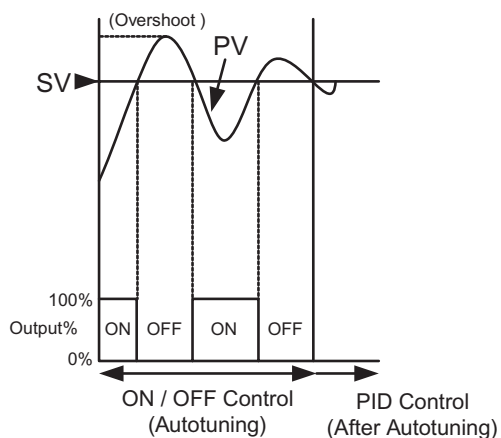

Autotuning
ATVL=20

*Set ATVL to prevent overshoot occurred during autotuning process.

To set ATVL ,press **SET** key 5 seconds to enter Level 2 (PID Level) and then change the value.

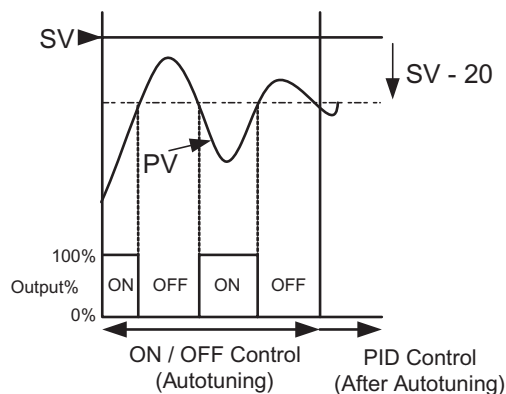

Autotuning failure

- Possible cause 1 : ATVL is too big. (If not sure , set ATVL=0)
- Possible cause 2 : Calculation time is too long. (Set PID parameter manually)

6.5 Programmable RAMP / SOAK (Only available for NC2738 model)

*For detail of the programmable instruction, please refer with page 25.

Assume the temperature profile is as below (use total 4 segments)

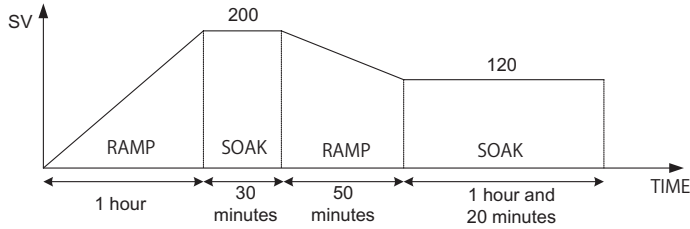

Please operate controller as following steps:

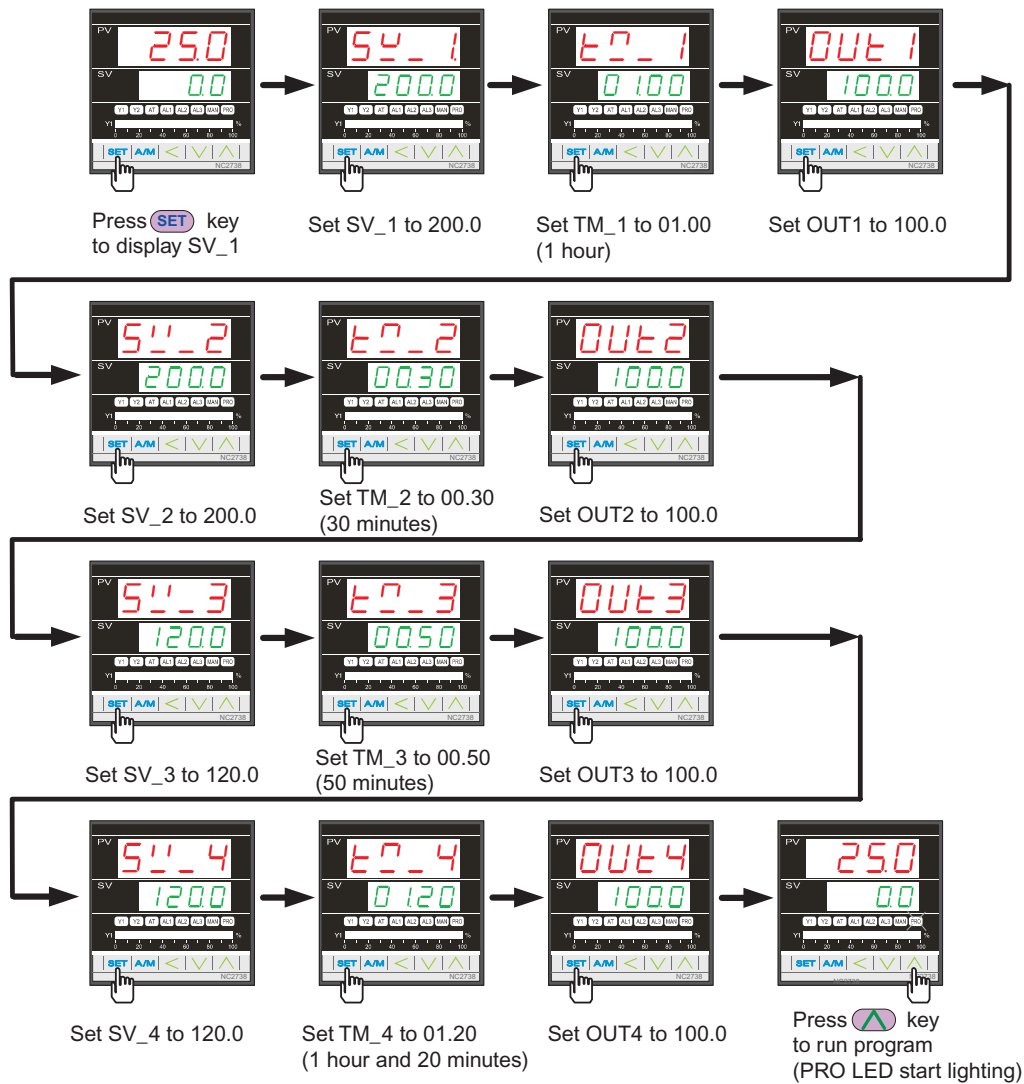

7. Operation levels

7.1 Levels diagram

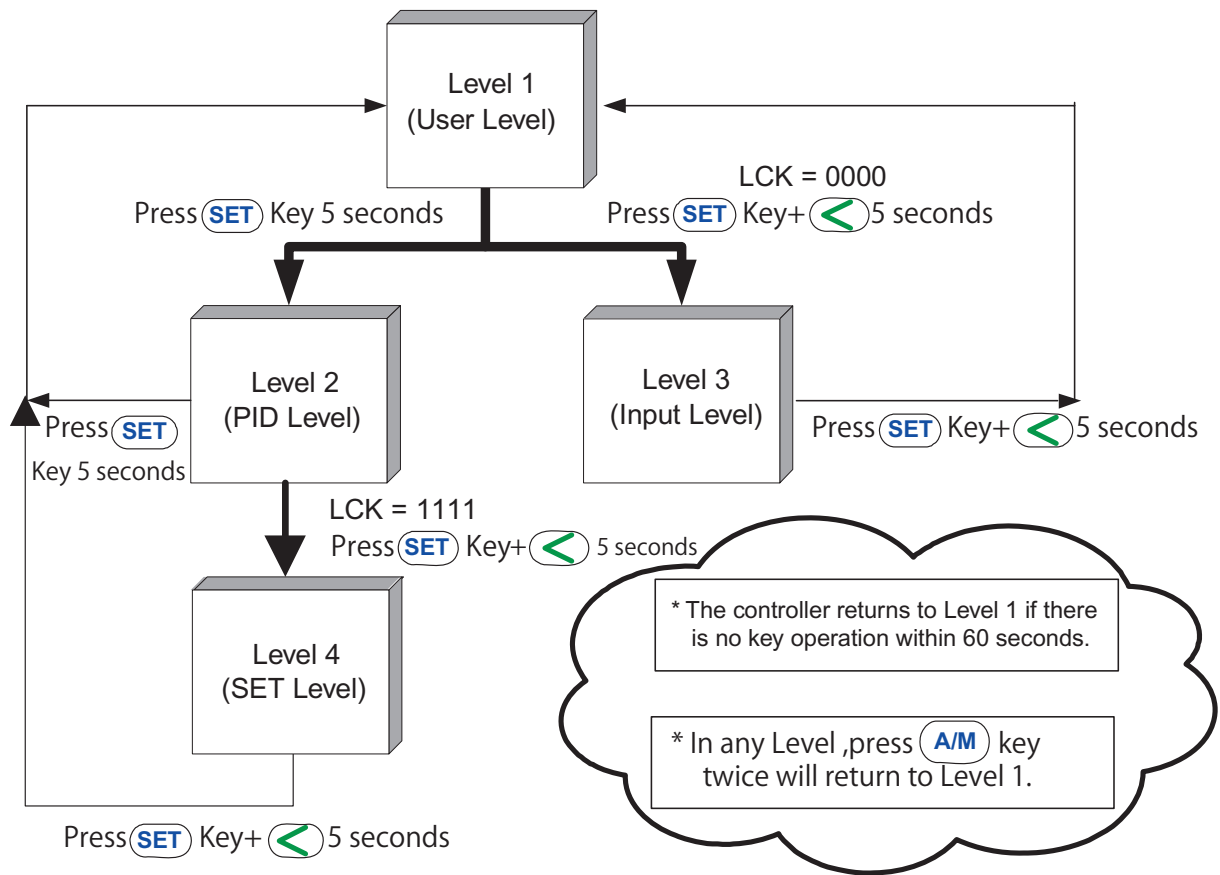

7.2 Lock function

To use lock function, please set parameter “LCK” in level 2.

LCK	Levels entering available				Parameters which can be changed
	Level 1 (User)	Level 2 (PID)	Level 3 (Input)	Level 4 (SET)	
0000	✓	✓	✓	X	All parameters (Factory set value)
1111	✓	✓	X	✓	All parameters
0100	✓	✓	X	X	All parameters except level 3
0110	✓	✓	X	X	Parameters in level 1
0001	✓	✓	X	X	“SV” and “LCK”
0101	✓	✓	X	X	Only “LCK”

8. Parameters

8.1 Level 1 (User Level)

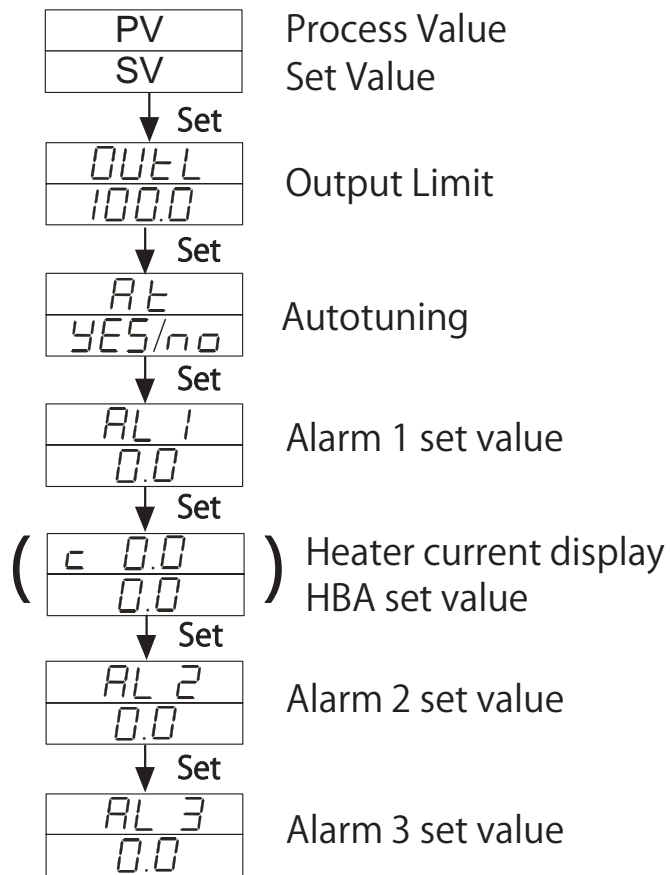

8.2 LEVEL 2 (PID Level)

To enter level 2, press SET key 5 seconds in level 1

8.2.1 Level 2 parameters display / hiding condition

1. Press **SET** key 5 seconds to enter level 2.
2. Set LCK to " 1111 " .
3. Press **SET** key and **<** key 5 seconds, to enter level 4 (Set level).
4. Set **OUTY** to " 0 " (Single output-P1) .

1. Press **SET** key 5 seconds to enter level 2.
2. Set LCK to " 1111 " .
3. Press **SET** key and **<** key 5 seconds, to enter level 4 (Set level).
4. Set **OUTY** to " 1 " (Dual output - P1/P2) .



8.2.2 Description of parameters

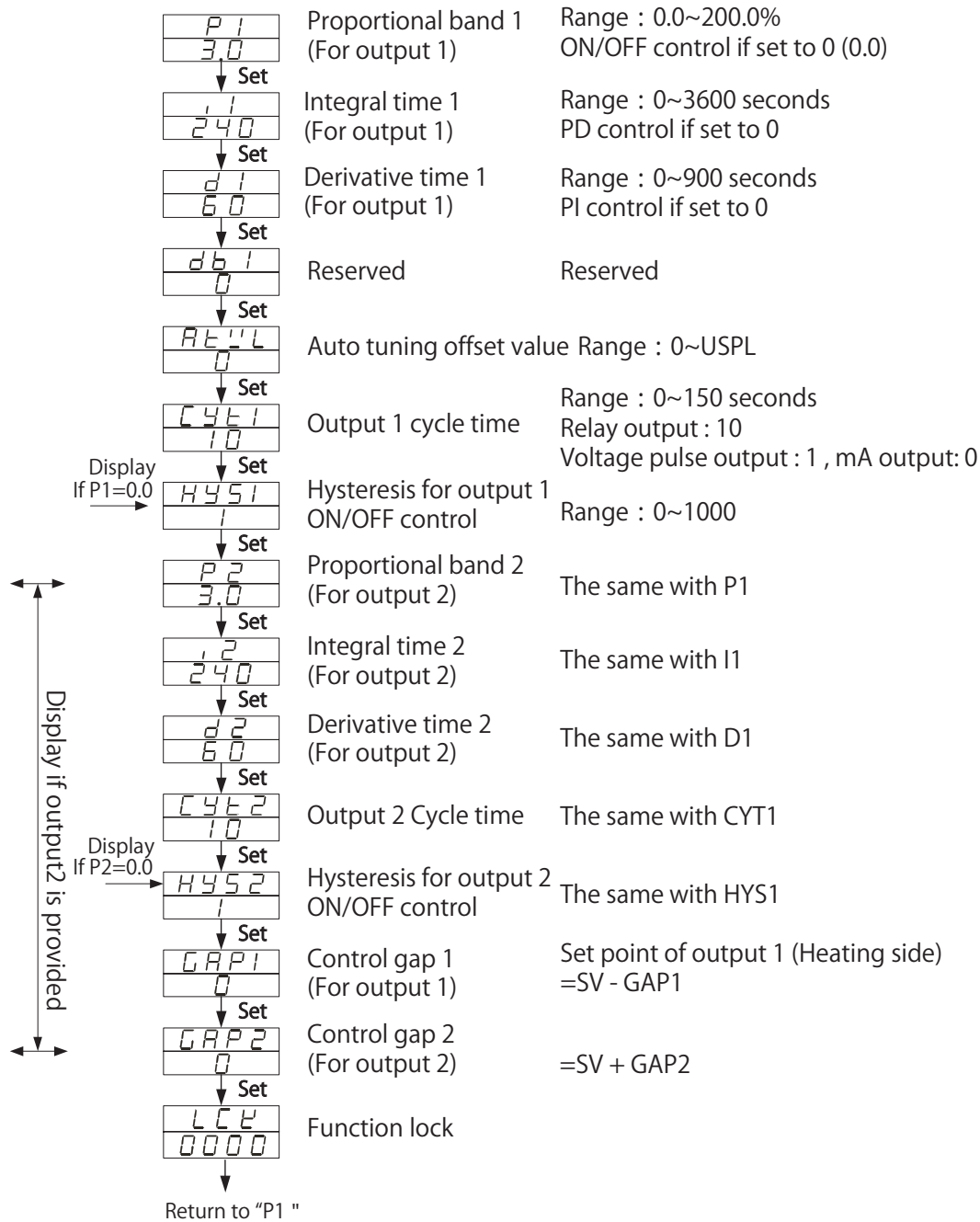

LCK	Levels entering available				Parameters which can be changed
	Level 1 (User)	Level 2 (PID)	Level 3 (Input)	Level 4 (SET)	
0000	✓	✓	✓	X	All parameters (default value)
1111	✓	✓	X	✓	All parameters
0100	✓	✓	X	X	All parameters except level 3
0110	✓	✓	X	X	Parameters in level 1
0001	✓	✓	X	X	"SV" and "LCK"
0101	✓	✓	X	X	Only "LCK"

8.3 LEVEL 3 (Input Level)

To enter level 3 , set LCK to "0000" and then press SET key + Shift(<) key 5 seconds.

<div style="border: 1px solid black; padding: 2px; display: inline-block;">INP1</div> <div style="border: 1px solid black; padding: 2px; display: inline-block;">E2</div>	Input type selection	
↓ Set		
<div style="border: 1px solid black; padding: 2px; display: inline-block;">ANL1</div> <div style="border: 1px solid black; padding: 2px; display: inline-block;">0</div>	Analog input low limit calibration (Used for mA and V input)	Range : -1999 ~ 9999
↓ Set		
<div style="border: 1px solid black; padding: 2px; display: inline-block;">ANH1</div> <div style="border: 1px solid black; padding: 2px; display: inline-block;">5000</div>	Analog input high limit calibration (Used for mA and V input)	Range : 0 ~ 9999
↓ Set		
<div style="border: 1px solid black; padding: 2px; display: inline-block;">dP</div> <div style="border: 1px solid black; padding: 2px; display: inline-block;">0000</div>	Decimal point position (Available for mA and V input)	0000 , 000.0 , 00.00 , 0.000
↓ Set		
<div style="border: 1px solid black; padding: 2px; display: inline-block;">L.S.P.L</div> <div style="border: 1px solid black; padding: 2px; display: inline-block;">0.0</div>	Lower Set-Point Limit	Scaling Low Limit
↓ Set		
<div style="border: 1px solid black; padding: 2px; display: inline-block;">U.S.P.L</div> <div style="border: 1px solid black; padding: 2px; display: inline-block;">400.0</div>	Upper Set-Point Limit	Scaling High Limit
↓ Set		
<div style="border: 1px solid black; padding: 2px; display: inline-block;">ANL2</div> <div style="border: 1px solid black; padding: 2px; display: inline-block;">0</div>	Remote input low limit calibration	Range : -1999 ~ 9999
↓ Set		
<div style="border: 1px solid black; padding: 2px; display: inline-block;">ANH2</div> <div style="border: 1px solid black; padding: 2px; display: inline-block;">5000</div>	Remote input high limit calibration	Range : 0 ~ 9999
↓ Set		
<div style="border: 1px solid black; padding: 2px; display: inline-block;">ALd1</div> <div style="border: 1px solid black; padding: 2px; display: inline-block;">11</div>	Alarm mode of AL1	Range:00~19 Refer to "Alarm mode type "
↓ Set		
<div style="border: 1px solid black; padding: 2px; display: inline-block;">ALt1</div> <div style="border: 1px solid black; padding: 2px; display: inline-block;">99.59</div>	Alarm time of AL1	Range : 0~99 Min 59 Secs 0=Flicker Alarm , 99:59=Continued Others=On delay time (If ALD=07 , ALT means alarm on time)
↓ Set		
<div style="border: 1px solid black; padding: 2px; display: inline-block;">ALd2</div> <div style="border: 1px solid black; padding: 2px; display: inline-block;">0</div>	Alarm mode of AL2	The same with ALD1
↓ Set		
<div style="border: 1px solid black; padding: 2px; display: inline-block;">ALt2</div> <div style="border: 1px solid black; padding: 2px; display: inline-block;">99.59</div>	Alarm time of AL2	The same with ALT1
↓ Set		
<div style="border: 1px solid black; padding: 2px; display: inline-block;">ALd3</div> <div style="border: 1px solid black; padding: 2px; display: inline-block;">0</div>	Alarm mode of AL3	The same with ALD1
↓ Set		
<div style="border: 1px solid black; padding: 2px; display: inline-block;">ALt3</div> <div style="border: 1px solid black; padding: 2px; display: inline-block;">99.59</div>	Alarm time of AL3	The same with ALT1
↓ Set		
<div style="border: 1px solid black; padding: 2px; display: inline-block;">HYSA</div> <div style="border: 1px solid black; padding: 2px; display: inline-block;">0.0</div>	Hysteresis of all Alarm	Range : 0~1000
↓ Set		
<div style="border: 1px solid black; padding: 2px; display: inline-block;">CL01</div> <div style="border: 1px solid black; padding: 2px; display: inline-block;">230</div>	Output 1 low limit calibration (Used for mA and V output)	Range : 0 ~ 9999
↓ Set		
<div style="border: 1px solid black; padding: 2px; display: inline-block;">CH01</div> <div style="border: 1px solid black; padding: 2px; display: inline-block;">3600</div>	Output 1 low limit calibration (Used for mA and V output)	Range : 0 ~ 9999
↓ Set		

<div style="border: 1px solid black; padding: 2px; display: inline-block;">CL02</div> <div style="border: 1px solid black; padding: 2px; display: inline-block;">230</div> ↓ Set	Output 2 low limit calibration (Used for mA and V output)	The same with CLO1
<div style="border: 1px solid black; padding: 2px; display: inline-block;">CH02</div> <div style="border: 1px solid black; padding: 2px; display: inline-block;">3600</div> ↓ Set	Output 2 high limit calibration (Used for mA and V output)	The same with CHO1
<div style="border: 1px solid black; padding: 2px; display: inline-block;">CL03</div> <div style="border: 1px solid black; padding: 2px; display: inline-block;">0</div> ↓ Set	Retransmission low limit calibration	The same with CLO1
<div style="border: 1px solid black; padding: 2px; display: inline-block;">CH03</div> <div style="border: 1px solid black; padding: 2px; display: inline-block;">5000</div> ↓ Set	Retransmission high limit calibration	The same with CHO1
<div style="border: 1px solid black; padding: 2px; display: inline-block;">rUcY</div> <div style="border: 1px solid black; padding: 2px; display: inline-block;">5</div> ↓ Set	Full run time of proportional motor (Used for proportional motor valve control output)	Range : 5~200 seconds
<div style="border: 1px solid black; padding: 2px; display: inline-block;">WAiT</div> <div style="border: 1px solid black; padding: 2px; display: inline-block;">0.0</div> ↓ Set	Used for programmable controller to wait continued operation	0=Not wait Others=Wait value
<div style="border: 1px solid black; padding: 2px; display: inline-block;">SEtA</div> <div style="border: 1px solid black; padding: 2px; display: inline-block;">0000</div> ↓ Set		
<div style="border: 1px solid black; padding: 2px; display: inline-block;">PSL</div> <div style="border: 1px solid black; padding: 2px; display: inline-block;">rTU</div> ↓ Set	Communication Protocol Selection: MODBUS RTU / MODBUS ASCII / TAIE	
<div style="border: 1px solid black; padding: 2px; display: inline-block;">bItS</div> <div style="border: 1px solid black; padding: 2px; display: inline-block;">0_81</div> ↓ Set	Communication Bits Configuration: O_81 /O_82/E_81/E_82	
<div style="border: 1px solid black; padding: 2px; display: inline-block;">Id.N0</div> <div style="border: 1px solid black; padding: 2px; display: inline-block;">1</div> ↓ Set	ID number	Range : 0 ~ 255
<div style="border: 1px solid black; padding: 2px; display: inline-block;">bAUd</div> <div style="border: 1px solid black; padding: 2px; display: inline-block;">384</div> ↓ Set	Baudrate	2400 / 4800 / 9600 / 19200 / 38400 bps
<div style="border: 1px solid black; padding: 2px; display: inline-block;">SV'05</div> <div style="border: 1px solid black; padding: 2px; display: inline-block;">0.0</div> ↓ Set	SV compensation	Range : -1000~1000
<div style="border: 1px solid black; padding: 2px; display: inline-block;">PV'05</div> <div style="border: 1px solid black; padding: 2px; display: inline-block;">0.0</div> ↓ Set	PV compensation	Range : -100.0~500.0
<div style="border: 1px solid black; padding: 2px; display: inline-block;">UNItE</div> <div style="border: 1px solid black; padding: 2px; display: inline-block;">C</div> ↓ Set	Unit of PV & SV	C (°C) / F (°F) / A (Analog)
<div style="border: 1px solid black; padding: 2px; display: inline-block;">PV'Ft</div> <div style="border: 1px solid black; padding: 2px; display: inline-block;">200</div> ↓ Set	PV Filter	PV will response faster if PVFT is smaller.
<div style="border: 1px solid black; padding: 2px; display: inline-block;">CAsC</div> <div style="border: 1px solid black; padding: 2px; display: inline-block;">0.0</div> ↓ Set	Reserved	
<div style="border: 1px solid black; padding: 2px; display: inline-block;">OUd</div> <div style="border: 1px solid black; padding: 2px; display: inline-block;">HEAt</div> ↓ Set	Control mode	Heat / Cool
<div style="border: 1px solid black; padding: 2px; display: inline-block;">OPAd</div> <div style="border: 1px solid black; padding: 2px; display: inline-block;">PId</div> ↓ Set	Control algorithm	PID / Fuzzy
<div style="border: 1px solid black; padding: 2px; display: inline-block;">H=</div> <div style="border: 1px solid black; padding: 2px; display: inline-block;">60Hz</div> ↓ Set	Frequency	50 / 60HZ
Return to "INP1 "		

8.4 Level 4 (SET level)

To enter level 4, set LCK to "1111" and then press SET key + Shift(\triangleleft) key 5 seconds.

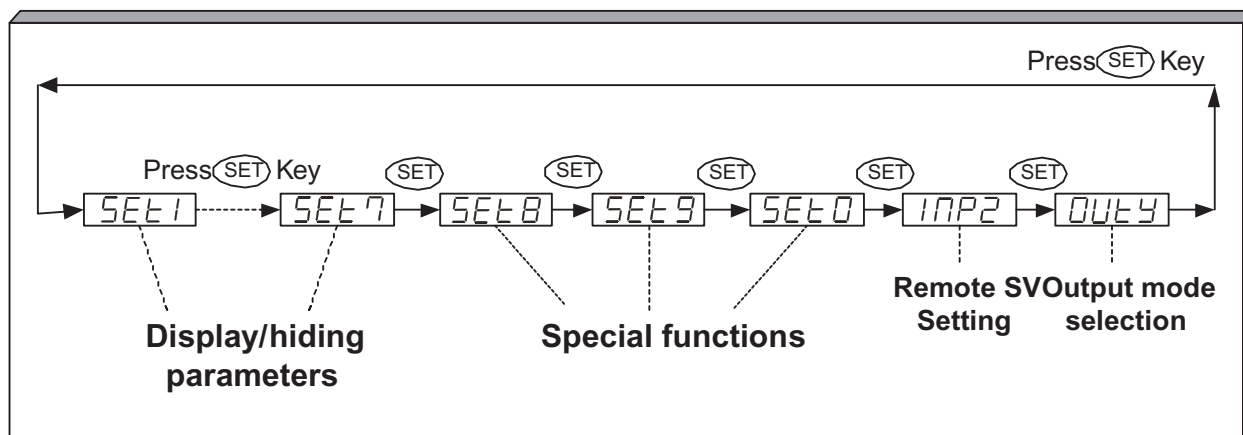

8.4.1 How to hide parameters (Use SET1~SET7)

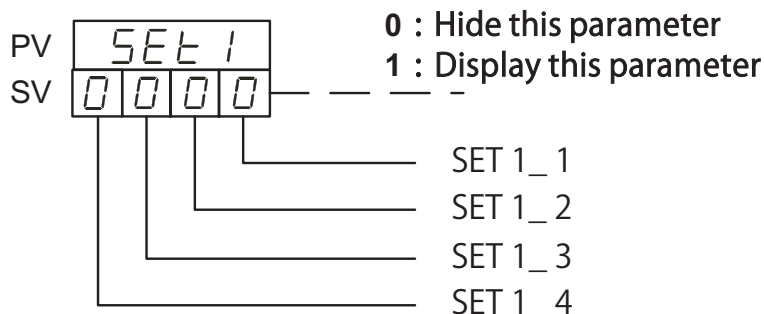

*For the description of Level 1 parameters, please refer with page 17.

*For the description of Level 3 parameters, please refer with page 20.

SET	Display / hiding	Level	SET	Display / hiding	Level
1_1	OUTL	Level 1	5_1	CLD2,CHD2	Level 3
1_2	AL	Level 1	5_2	CLD3,CHD3	Level 3
1_3	AL1	Level 1	5_3	r.u.c.y, u.a.r.t, s.e.t.a	Level 3
1_4	AL2	Level 1	5_4	p.s.l, b.i.t.s, i.d.n.o, b.a.u.d	Level 3
2_1	AL3	Level 1	6_1	s'u.o.s	Level 3
2_2	ANL1, ANH1, dP	Level 3	6_2	p'u.o.s	Level 3
2_3	L.S.P.L, U.S.P.L	Level 3	6_3	u.n.i.t	Level 3
2_4	ANL2, ANH2	Level 3	6_4	p'u.f.t	Level 3
3_1	ALd1	Level 3	7_1	C.A.S.C	Level 3
3_2	ALt1	Level 3	7_2	O.U.d	Level 3
3_3	ALd2	Level 3	7_3	O.P.A.d	Level 3
3_4	ALt2	Level 3	7_4	H =	Level 3
4_1	ALd3	Level 3			
4_2	ALt3	Level 3			
4_3	H.Y.S.A	Level 3			
4_4	CLD1, CHD1	Level 3			

8.4.2 Special functions (Use SET8 / SET9 / SET0)

SET 8		Remark
8_1	0 : Program not repeat	Only available for programmable controller
	1 : Program repeat	
8_2	0 : No power failure option	
	1 : With power failure option	
8_3	0 : Program starts from 0	
	1 : Program starts from PV	
8_4	0 : Reserved (Don't change it)	

SET 9		Remark
9_1	0 : Reserved (Don't change it)	
9_2	0 : Timer Unit = "Hour : Minute"	Only available for programmable controller
	1 : Timer Unit = "Minute : Second"	
9_3	0 : Disable transmission	Used for transmission output
	1 : SV Transmission	
9_4	0 : Disable transmission	
	1 : PV Transmission	

SET 0		Remark
0_1	0 : TTL Communication (Slave)	Used for TTL communication
	1 : TTL Communication (Master)	
0_2	0 : Hide parameter "RATE"	AI3 will be replaced by "RATE"
	1 : Display parameter "RATE"	
0_3	0 : Disable Remote SV function	Used for Remote SV function
	1 : Enable Remote SV function	
0_4	0 : use output relay "b" contact when motor valve closed	Used for 3 wire proportional motor valve control
	1 : use output relay "a" contact when motor valve closed	

Please don't operate **SET 8_4** , otherwise the controller's process will be in Mirror display.

If SET8.4 is set to "1", the controller will enter into "Single Display" mode, the PV LED will not display any values. The SV LED will display both the parameter value and the setting value alternately as shown in the diagram below.

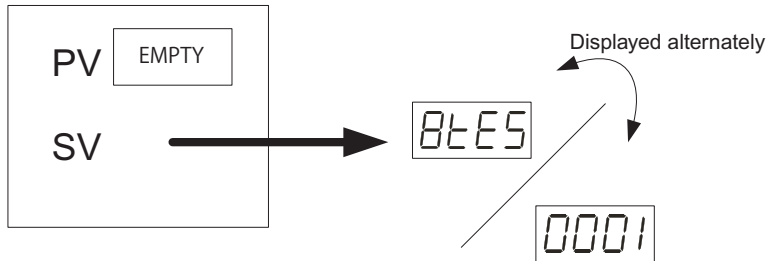

To rectify the problem please press the SHIFT KEY (\triangleleft) and change the setting value to "0000".

8.4.3 Remote SV type selection

INP2=0 None

INP2=1 10~50mV / 4~20mA / 1~5V / 2~10V

INP2=2 0~50mV / 0~20mA / 0~5V / 0~10V

INP2=4 CT input

Δ Remote SV function is not available for programmable controller

8.4.4 Output mode selection (Use OUTY)

OUTY=0 Single output (OUT1)

OUTY=1 Dual output (OUT1 / OUT2)

OUTY=2 Reserved

OUTY=3 3 wire proportional motor valve control

OUTY=4 1 \emptyset Phase angle control (1 \emptyset SCR)

OUTY=5 3 \emptyset Phase angle control (3 \emptyset SCR)

8.5 Program Level (Only displayed in programmable controller)

8.5.1 Description of parameters

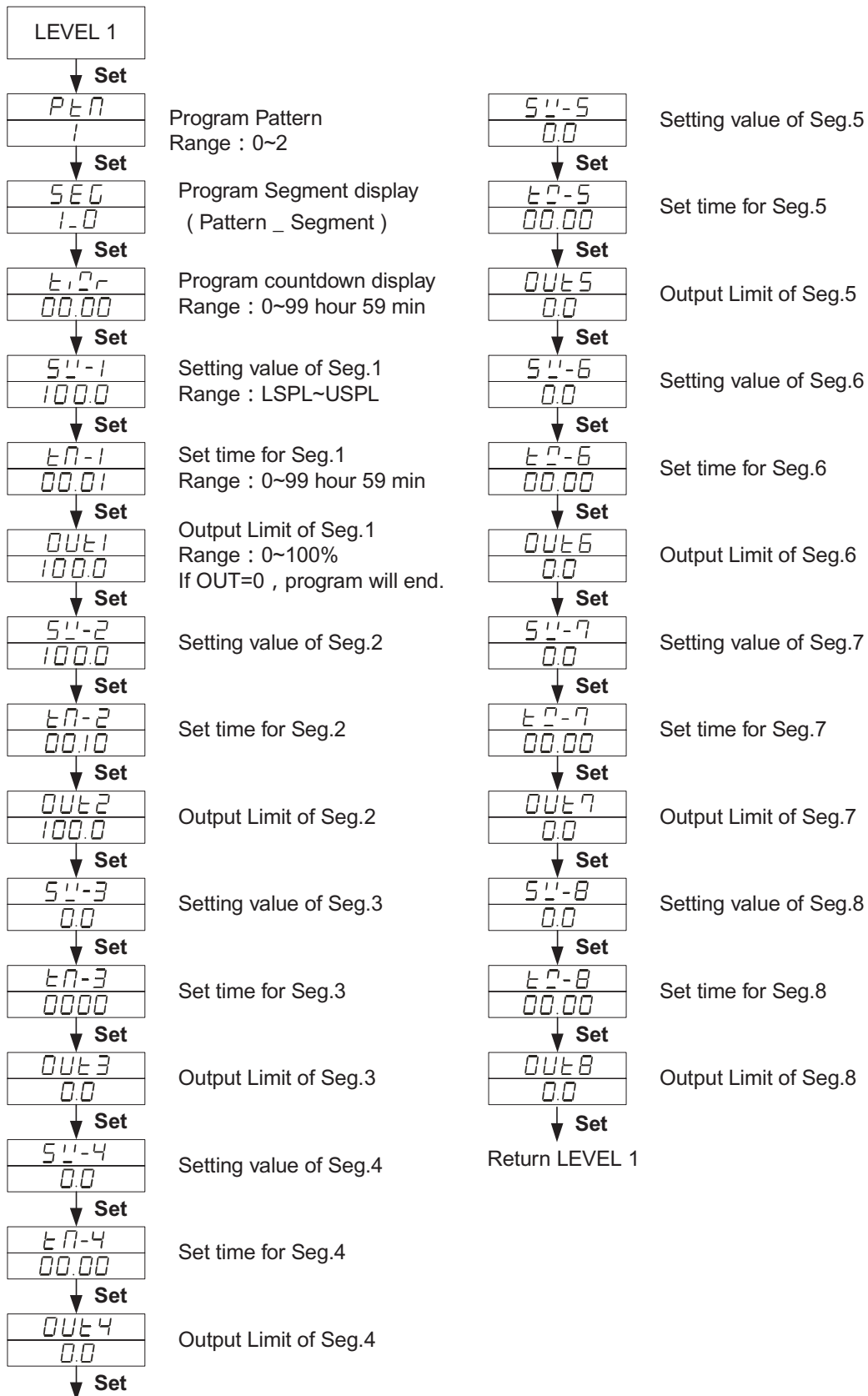

8.5.2 Description of operation

1. There are 2 patterns can be used , each pattern contains 8 segments.

2. Terminologies

Pattern : A program consists of some steps.

Ramp status : The status with changing SV.

Soak status : The status with fixed SV.

3. Operating

I. "KEY" function (no changing parameter)

△(RUN) : Start program procedure , **PRO** LED in panel start flicking.

▽(HOLD) :Suspend program procedure , **PRO** LED in panel will steady

△ + **SET**(JUMP) : Jump to previous segment.

▽ + **SET** (RESET) : Reset program procedure , **PRO** LED in panel will off.

II. Alarm Function :

ALD1 = "07"(Segment end alarm) ,

AL1 = "2"(It means when segment 2 end,AL1 will act) ,

ALT1 = "00:10"(Relay on time is 10 seconds).

* In this case , when program proceeds to segment 2 end , the relay of AL1 will be on 10 seconds.

III. END function :

The Controller doesn't have END order, so if program procedure is less than 8 segments, please set the last segment's OUT to "0". Program will end in this segment. Otherwise , it will proceed 8 or 16 segments.

IV. Linking Function :

PTN=1 proceed pattern 1 , contains 8 segments.

PTN=2 proceed pattern 2 , contains 8 segments.

PTN=0 linking proceed pattern 1 and 2 totally 16 segments.

(Please set PTN1 and PTN2 at first , and then set PTN to 0)

V. Other function (✕refer to LEVEL 4)

SET 8_1=1 Program repeats.

SET 8_2=0 No power failure function.

SET 8_2=1 Enable power failure function.

(When power shut down and on again , the controller will start from the segment which is near PV)

SET 8_3=0 Program starts from 0.

SET 8_3=1 Program starts from PV.

SET 9_2=0 Timer Unit = "Hour : Minute"

SET 9_2=1 Timer Unit = "Minute : Second"

9. Input type table (INP1 selection)

TYPE	CODE	RANGE
K	<i>K1</i>	0.0 ~ 200.0°C / 0.0 ~ 392.0°F
	<i>K2</i>	0.0 ~ 400.0°C / 0.0 ~ 752.0°F
	<i>K3</i>	0 ~ 600°C / 0 ~ 1112°F
	<i>K4</i>	0 ~ 800°C / 0 ~ 1472°F
	<i>K5</i>	0 ~ 1000°C / 0 ~ 1832°F
	<i>K6</i>	0 ~ 1200°C / 0 ~ 2192°F
J	<i>J1</i>	0.0 ~ 200.0°C / 0.0 ~ 392.0°F
	<i>J2</i>	0.0 ~ 400.0°C / 0.0 ~ 752.0°F
	<i>J3</i>	0 ~ 600°C / 0 ~ 1112°F
	<i>J4</i>	0 ~ 800°C / 0 ~ 1472°F
	<i>J5</i>	0 ~ 1000°C / 0 ~ 1832°F
	<i>J6</i>	0 ~ 1200°C / 0 ~ 2192°F
R	<i>R1</i>	0 ~ 1600°C / 0 ~ 2912°F
	<i>R2</i>	0 ~ 1769°C / 0 ~ 3216°F
S	<i>S1</i>	0 ~ 1600°C / 0 ~ 2912°F
	<i>S2</i>	0 ~ 1769°C / 0 ~ 3216°F
B	<i>B1</i>	0 ~ 1820°C / 0 ~ 3308°F
E	<i>E1</i>	0 ~ 800°C / 0 ~ 1472°F
	<i>E2</i>	0 ~ 900°C / 0 ~ 1652°F
N	<i>N1</i>	0 ~ 1200°C / 0 ~ 2192°F
	<i>N2</i>	0 ~ 1300°C / 0 ~ 2372°F
T	<i>T1</i>	-199.9 ~ 400.0°C / -199.9 ~ 752.0°F
	<i>T2</i>	-199.9 ~ 200.0°C / -199.9 ~ 392.0°F
	<i>T3</i>	0.0 ~ 350.0°C / 0.0 ~ 662.0°F
W5Re/W26Re	<i>W1</i>	0 ~ 2000°C / 0 ~ 3632°F
	<i>W2</i>	0 ~ 2320°C / 0 ~ 4208°F
PL	<i>PL1</i>	0 ~ 1300°C / 0 ~ 2372°F
	<i>PL2</i>	0 ~ 1390°C / 0 ~ 2534°F
U	<i>U1</i>	-199.9 ~ 600.0°C / -199.9 ~ 999.9°F
	<i>U2</i>	-199.9 ~ 200.0°C / -199.9 ~ 392.0°F
	<i>U3</i>	0.0 ~ 400.0°C / 0.0 ~ 752.0°F
L	<i>L1</i>	0 ~ 400°C / 0 ~ 752°F
	<i>L2</i>	0 ~ 800°C / 0 ~ 1472°F

TYPE	CODE	RANGE
JIS PT100	<i>JP1</i>	-199.9 ~ 600.0°C / -199.9 ~ 999.9°F
	<i>JP2</i>	-199.9 ~ 400.0°C / -199.9 ~ 752.0°F
	<i>JP3</i>	-199.9 ~ 200.0°C / -199.9 ~ 392.0°F
	<i>JP4</i>	0 ~ 200°C / 0 ~ 392°F
	<i>JP5</i>	0 ~ 400°C / 0 ~ 752°F
	<i>JP6</i>	0 ~ 600°C / 0 ~ 1112°F
DIN PT100	<i>dP1</i>	-199.9 ~ 600.0°C / -199.9 ~ 999.9°F
	<i>dP2</i>	-199.9 ~ 400.0°C / -199.9 ~ 752.0°F
	<i>dP3</i>	-199.9 ~ 200.0°C / -199.9 ~ 392.0°F
	<i>dP4</i>	0 ~ 200°C / 0 ~ 392°F
	<i>dP5</i>	0 ~ 400°C / 0 ~ 752°F
	<i>dP6</i>	0 ~ 600°C / 0 ~ 1112°F
JIS PT50	<i>dP.1</i>	-199.9 ~ 600.0°C / -199.9 ~ 999.9°F
	<i>dP.2</i>	-199.9 ~ 400.0°C / -199.9 ~ 752.0°F
	<i>dP.3</i>	-199.9 ~ 200.0°C / -199.9 ~ 392.0°F
	<i>dP.4</i>	0 ~ 200°C / 0 ~ 392°F
	<i>dP.5</i>	0 ~ 400°C / 0 ~ 752°F
	<i>dP.6</i>	0 ~ 600°C / 0 ~ 1112°F
AN1	<i>AN1</i>	-10 ~ 10mV / -1999~9999
AN2	<i>AN2</i>	0 ~ 10mV / -1999~9999
AN3	<i>AN3</i>	0 ~ 20mV / -1999~9999
AN4	<i>AN4</i>	0 ~ 50mV / -1999~9999
AN5	<i>AN5</i>	10 ~ 50mV / -1999~9999

* The initial setting in factory is "K2".

10. Alarm

10.1 Alarm time (ALT1/ALT2/ALT3)

- ALT1=0 Flicker alarm
- ALT1=99.59 Continued alarm
- ALT1=00.01 ~ 99.58 Alarm on delay time





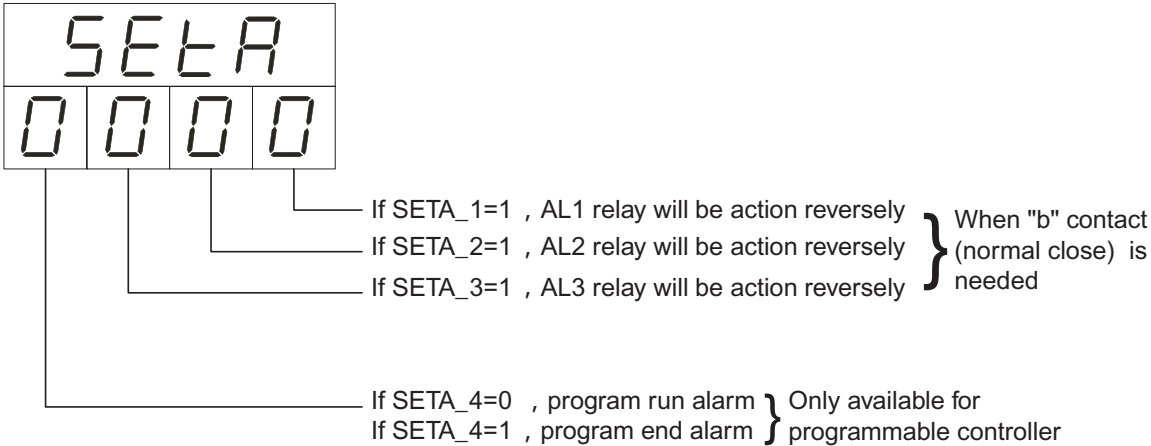





10.2 SETA

*SETA is in Level 3 (Input level)

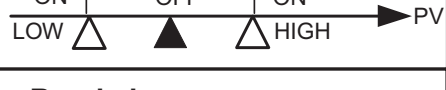

10.3 Alarm mode (ALD1 / ALD2 / ALD3)

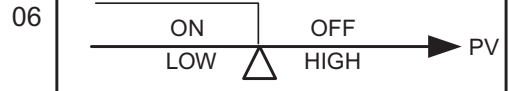
(▲ :SV △ :Alarm set value)

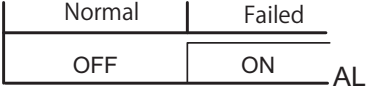
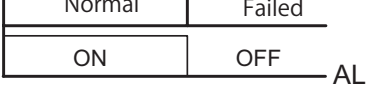
01	Deviation high alarm with hold action* 
11	Deviation high alarm 
02	Deviation low alarm with hold action* 
12	Deviation low alarm 
03	Deviation high/low alarm with hold action* 
13	Deviation high/low alarm 
04 14	Band alarm 
05	Process high alarm with hold action* 
15	Process high alarm 
06	Process low alarm with hold action* 
16	Process low alarm 
07	Segment End alarm (Only for Programmable controller) (1) ALD1~3 , set 07 (2) ALD1~3=Alarm Segment (3) ALT1~3 defines as follows: 0 =flicker alarm 99.59 =continued alarm others =alarm ON time
17	Program Run alarm (Only for Programmable controller) 
08	System failed alarm* (ON) 
18	System failed alarm* (OFF) 
09	Heater Break Alarm (HBA) Please refer with HBA function description in page 31.
00 10	No alarm

***Hold action:**

When Hold action is ON ,the alarm action is suppressed at start-up until the measured value(PV) enters the non-alarm range.

***System failed:**

It means that the controller display error message with one of following :
 “UUU1” or “NNN1” or “CJCE”

11.Heater Break Alarm (HBA)

11.1 HBA Wiring Example

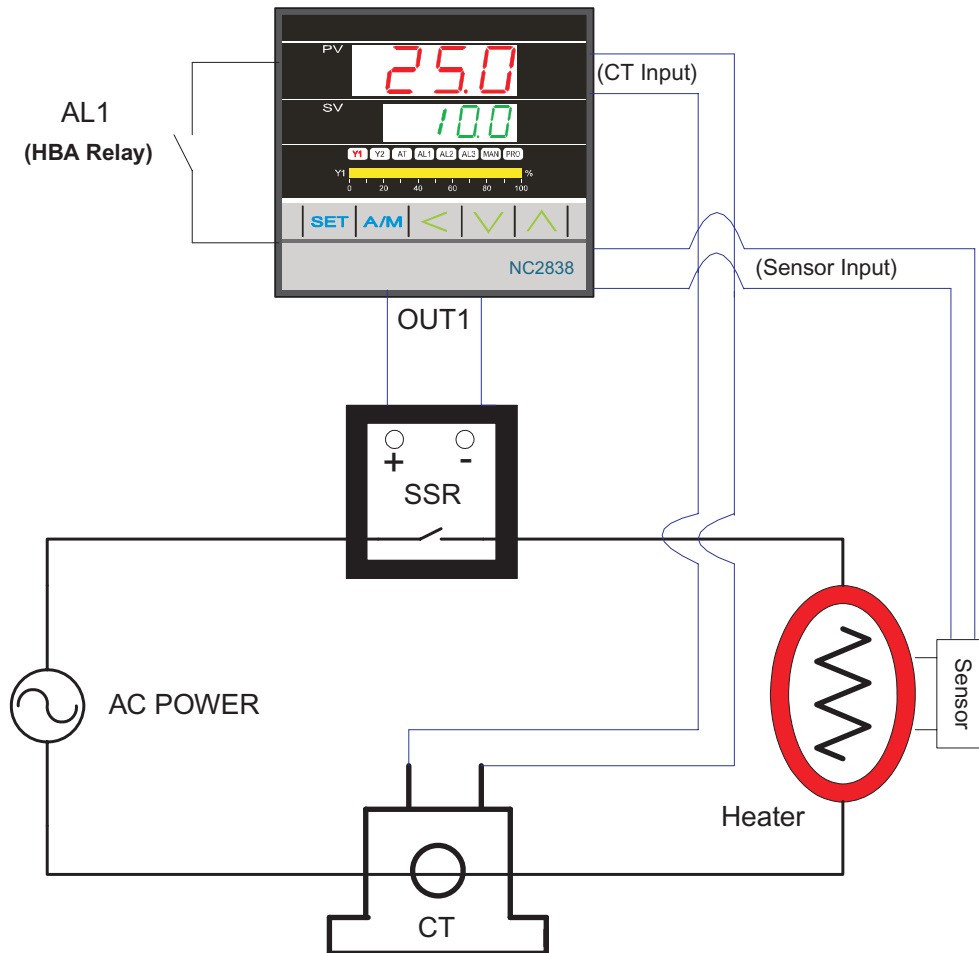

11.2 HBA Function Description

HBA function detects the AC current flowing through the heater by a Current Transformer (CT), and compares the CT input value and HBA set value. When OUT1 is ON and CT input value is less than HBA set value during 5 seconds , AL1 is activated. Otherwise, AL1 is not activated.

The AC current flowing through heater can also be monitored in HBA setting mode.

11.3 HBA setting procedure

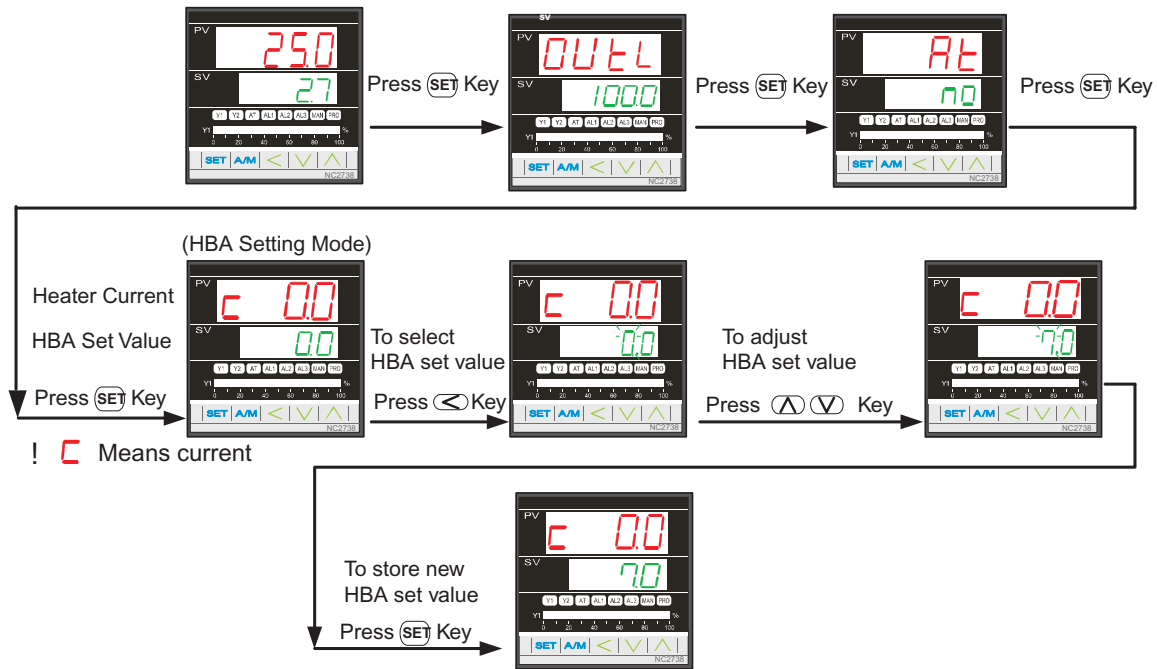

11.4 Parameters for HBA function

Name	Value	Operation Level
AL1	HBA Set Value	Level 1
ALD1	9	Level 3
SET0	0100	Level 4
INP2	4	Level 4

- > How to enter Level 3 : Set parameter “LCK”to 0000 in Level 2 , and then press “SET” key + “Shift” key 5 seconds to enter operation Level 3.
- > How to enter Level 4 : Set parameter “LCK”to 1111 in Level 2 , and then press “SET” key + “Shift” key 5 seconds to enter operation Level 4.

11.5 Activated conditions of HBA

Condition
1. OUT1 is ON
2. Heater current is less the HBA set value
3. Condition1 and 2 continued more than 5 seconds

AL1 will be activated, if condition 1 & 2 & 3 are all "true".

11.6 Remarks

- > Available output(OUT1) type for HBA
 - I. Relay
 - II. Voltage pulse (SSR drive)

- > Since HBA function uses AL1 as alarm relay, please set temperature alarms in AL2 or AL3.

12. Error codes

DISPLAY	DESCRIPTION
<i>in1E</i>	Open circuit of main control sensor.(INP1)
* <i>AdCF</i>	A/D convert failed.
* <i>EJCE</i>	Cold junction compensation failed.
<i>in2E</i>	Open circuit of sub control sensor.(Remote SV)
<i>uuu1</i>	PV exceeds USPL.
<i>nnn1</i>	PV under LSPL.
<i>uuu2</i>	Input signal of sub control exceeds the upper limit. (Remote SV)
<i>nnn2</i>	Input signal of sub control under the lower limit. (Remote SV)
* <i>FR0F</i>	RAM failed.
<i>inEF</i>	Interface failed.
<i>AU0F</i>	Auto tuning failed.

NOTE : If the “☆” marked error comes up , the controller needs to be repaired.
Please send it to the nearest sales office or retail dealer.

13. Modify input type (“TC” \rightleftharpoons “RTD”)

If the controller needs to modify input type from **TC** or **mV** to **RTD** , please make PAD short on the back side of PC board as following diagram and change input selection(INP1). On the contrary , modify from **RTD** to **TC** or **mV** , make PAD open.

96x96,48x96,96x48(mm)

RTD : Short pads

TC or mV : Open pads

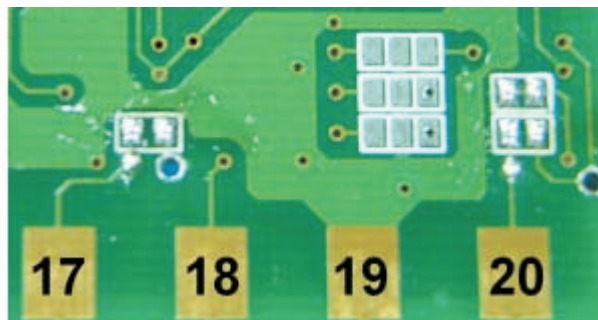
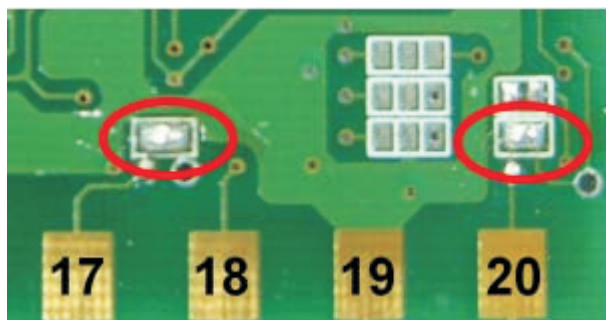

72x72(mm)

RTD : Short pads

TC or mV : Open pads

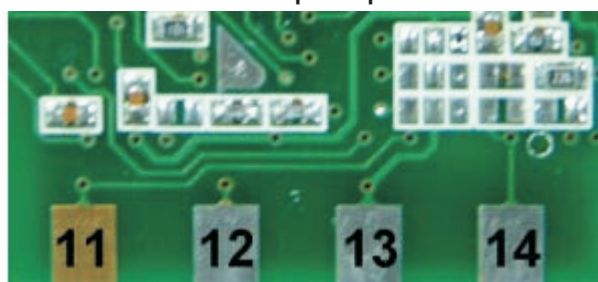
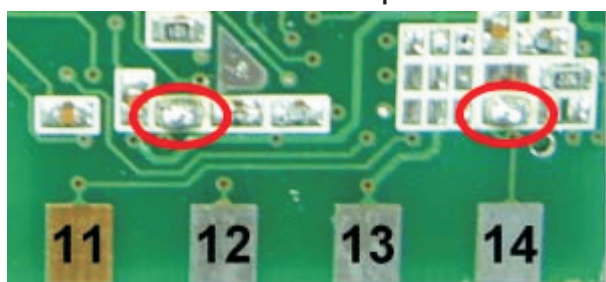

48x48(mm)

RTD : Short pads

TC or mV : Open pads

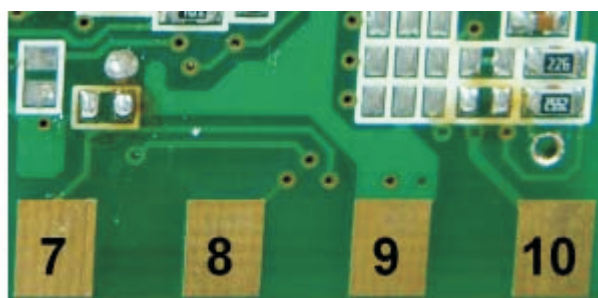
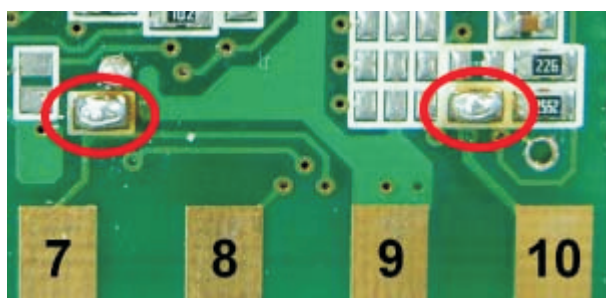

14. Modify input type : Linear Input (mA ,V)

14.1 Hardware :

	96×96 , 48×96 , 96×48	72×72	48×48
INPUT (+)	PIN 17	PIN 11	PIN 7
INPUT (-)	PIN 20	PIN 14	PIN 10

0~20mA (INP1=AN4) : (R3 use 100Ω , R5 use 2.4Ω , S3 & S5 SHORT)

4~20mA (INP1=AN5) : (R3 use 100Ω , R5 use 2.4Ω , S3 & S5 SHORT)

0 ~ 1V (INP1=AN4) : (R1 use 2KΩ , R4 use 100Ω , S1 & S4 SHORT)

0 ~ 5V (INP1=AN4) : (R2 use 10KΩ , R4 use 100Ω , S2 & S4 SHORT)

1 ~ 5V (INP1=AN5) : (R2 use 10KΩ , R4 use 100Ω , S2 & S4 SHORT)

0 ~ 10V (INP1=AN4) : (R3 use 22KΩ , R4 use 100Ω , S3 & S4 SHORT)

2 ~ 10V (INP1=AN5) : (R3 use 22KΩ , R4 use 100Ω , S3 & S4 SHORT)

96×96 , 48×96 , 96×48

(PC Board)

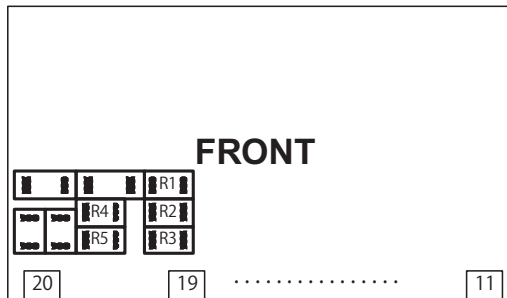

72×72
(PC Board)

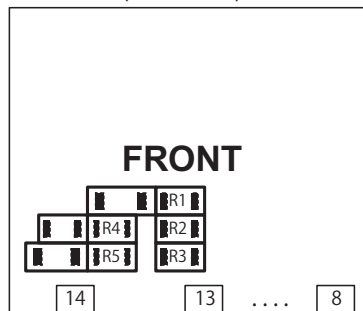

48×48
(PC Board)

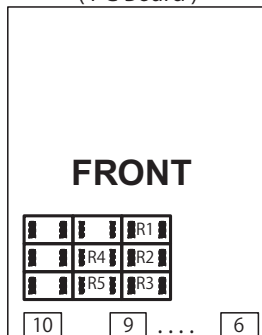

96×96 , 48×96 , 96×48

(PC Board)

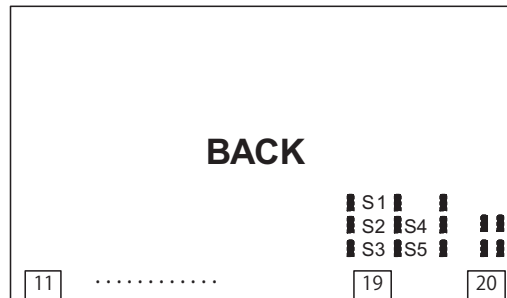

72×72
(PC Board)

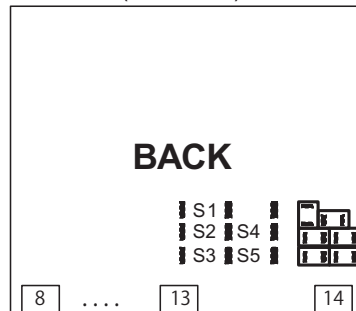

48×48
(PC Board)

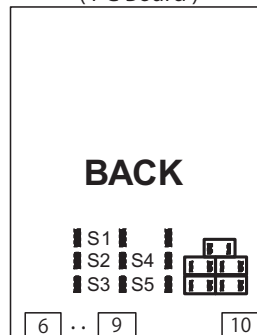

14.2 Calibration :

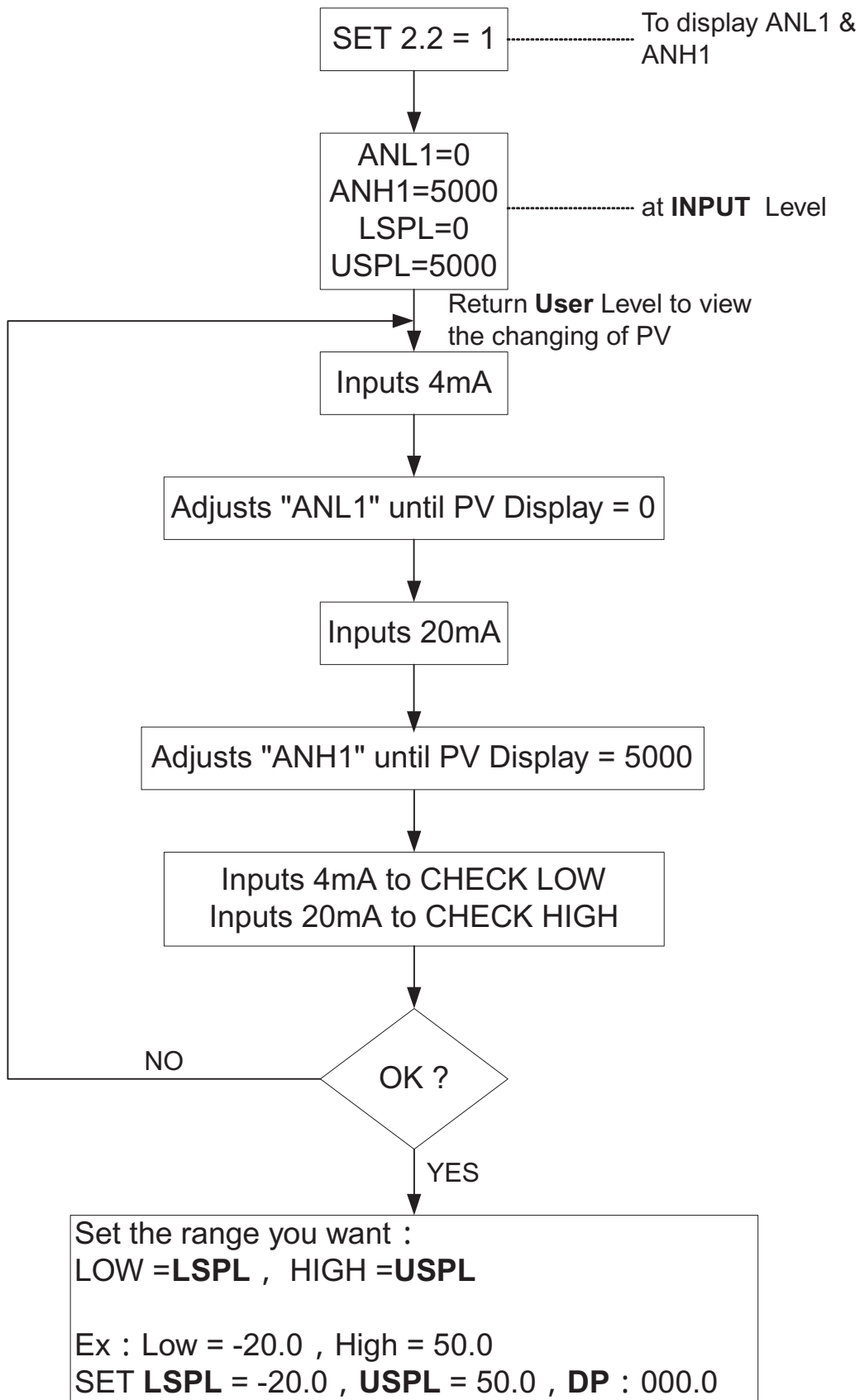

15. Modify output type : Linear output (mA ,V)

It just needs to change a module at the same position ,
and modify parameter **CYT1** in LEVEL 2 .

Δ Relay: CYT1=10, Voltage pulse : CYT1=1, 4~20mA:CYT1=0

16. Modify output mode: OUT1/ALARM, OUT1/OUT2

OUT1 / ALARM

96X96 , 48X96 , 96X48
(CPU Board)

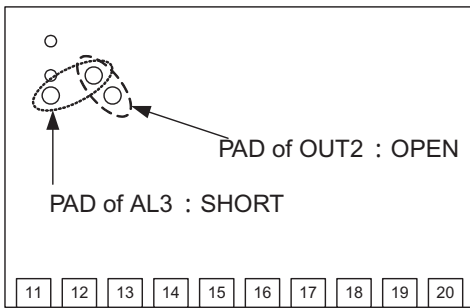

OUT1 / OUT2

96X96 , 48X96 , 96X48
(CPU Board)

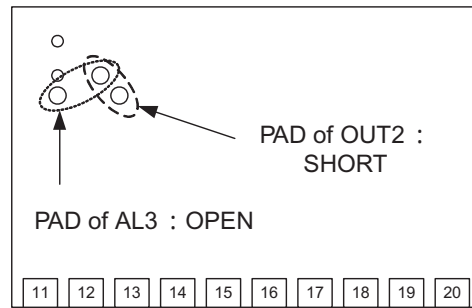

72 × 72
(CPU Board)

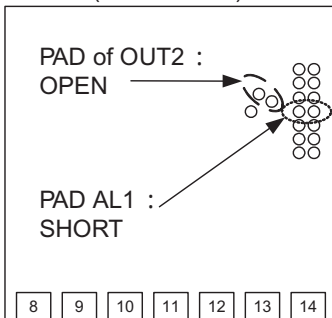

72 × 72
(CPU Board)

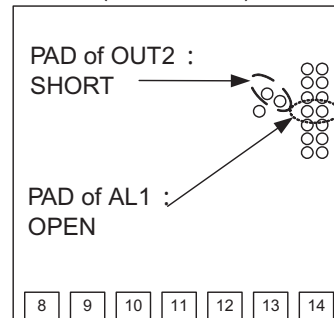

48 × 48
(CPU Board)

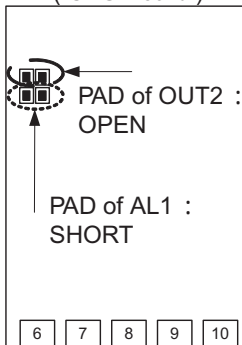

48 × 48
(CPU Board)

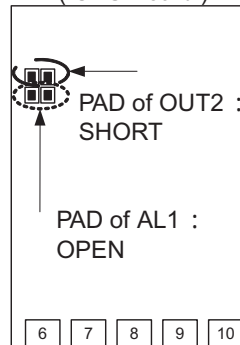

17. Applications

17.1 RAMP & SOAK

Δ RAMP :

- I. SET2.1=1 » To display AL3
- II. SET4.1=1 » To display ALD3
- III. ALD3=9 » Open RAMP option
- IV. Then, AL3 will not display. It was replaced by RAMP.

RAMP
00.00

Range : 00.00 ~ 99.99(°C/ min)
 (If RAMP is not used , please set
 ALD3 to 0)

Δ SOAK:

- I. ALD1 / ALD2=19 Δ To use Sock Timer.
- II. AL1 / AL2 will display as below:

AL1
00.00

Range : 00.00 ~ 99.59(Hour.Minute)

Δ Example:

SV=100°C ,RAMP=10.00 (°C/ min) , AL1=00.10 min , PV=25°C

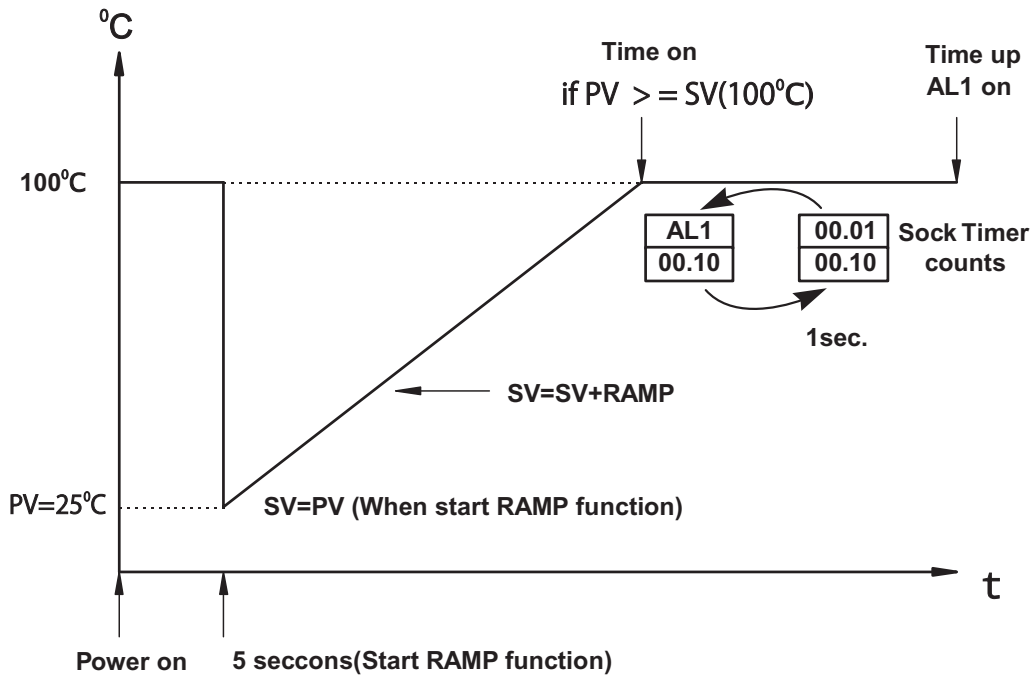

17.2 TTL Communication : SV output and RATE function

△ Open RATE function (use for slave controller)

Display AL3 : SET2.1=1

Display ALD3 : SET4.1=1

Display RATE(AL3 will be replaced) : SET0.2=1

Set ALD3 to 0. (In Level 3)

Slave SV = (RATE ÷ 9999) × master SV

△ Example :

Connection Diagram

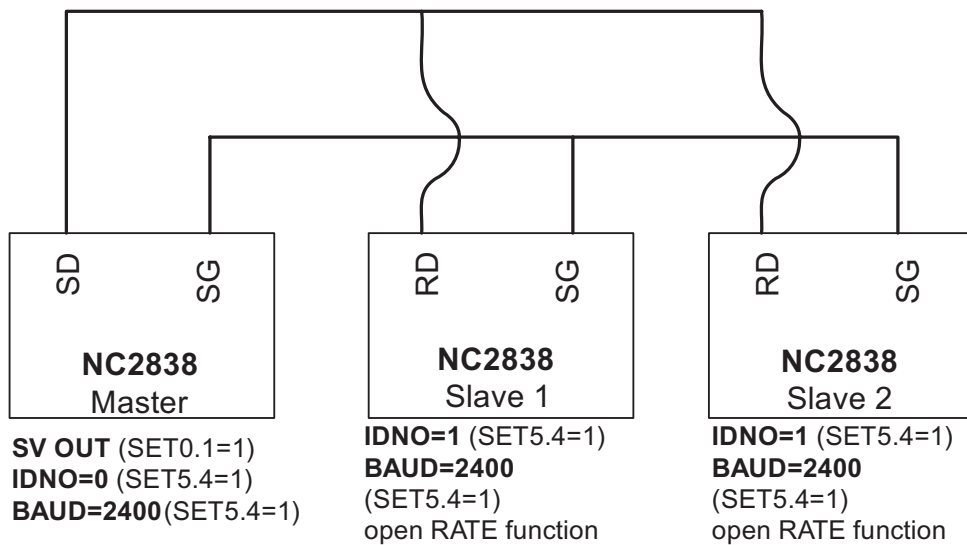

Time Chart

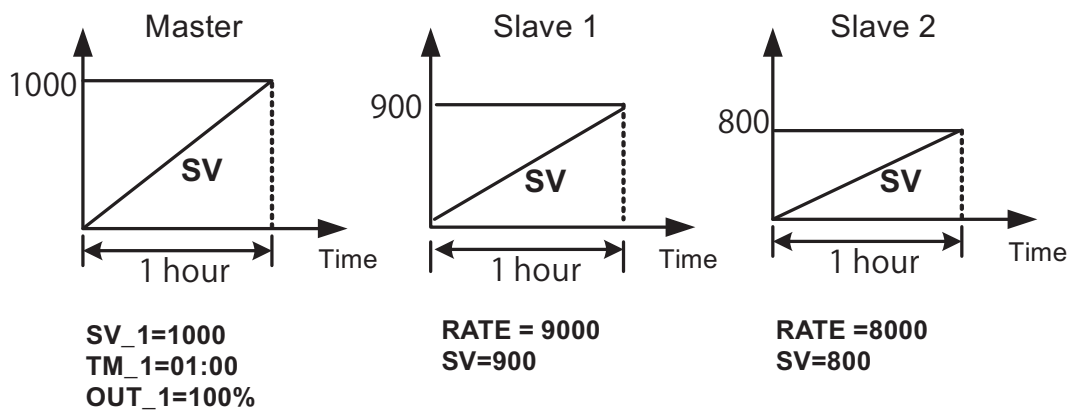

(Three controllers reach to the max value at the same time)

17.4 1Ø Phase angle control (By TRIAC)

△ Available Models : NC2838 / NC2838P, NC2738 / NC2738P

△ OUT1: 1Ø SCR phase angle control

△ Parameter setting : OUTY=4

CLO1=0 , CHO1=4500 if use for resistance load

CLO1=0 , CHO1=4000 if use for inductive load

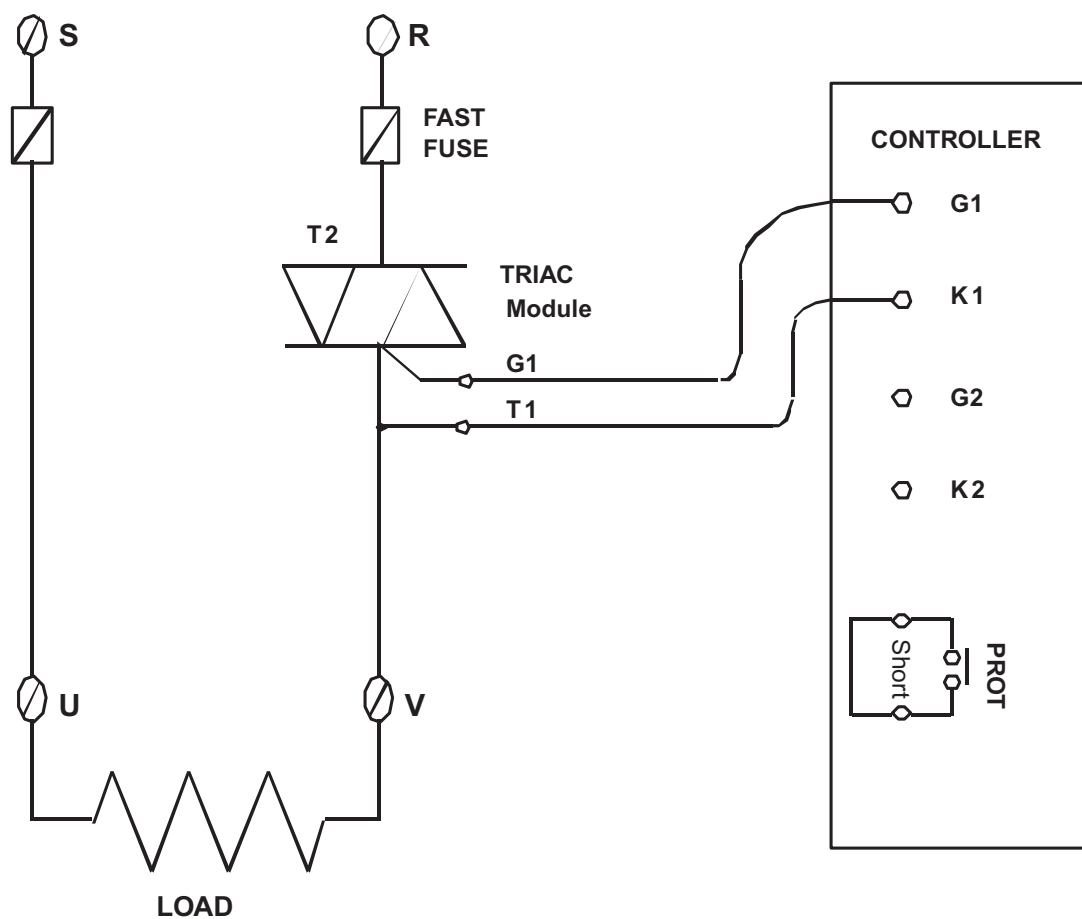

** Controller source phase must be same as load source phase

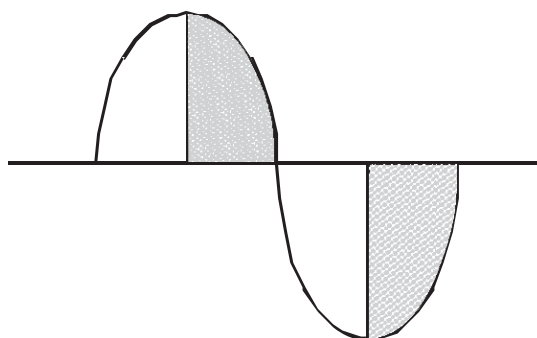
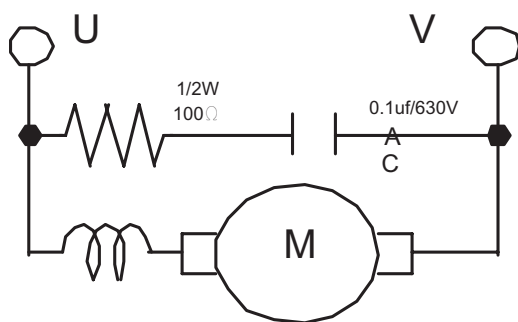

17.5 3Ø Phase angle control (By DIODE/SCR module)

△ Available Models : NC2838 / NC2838P

△ OUT1: 3Ø SCR phase angle control

△ Parameter setting : OUTY=5

CLO1=0 , CHO1=4500 only if use for resistance load

CLO1=0 , CHO1=4000 if use for inductive load

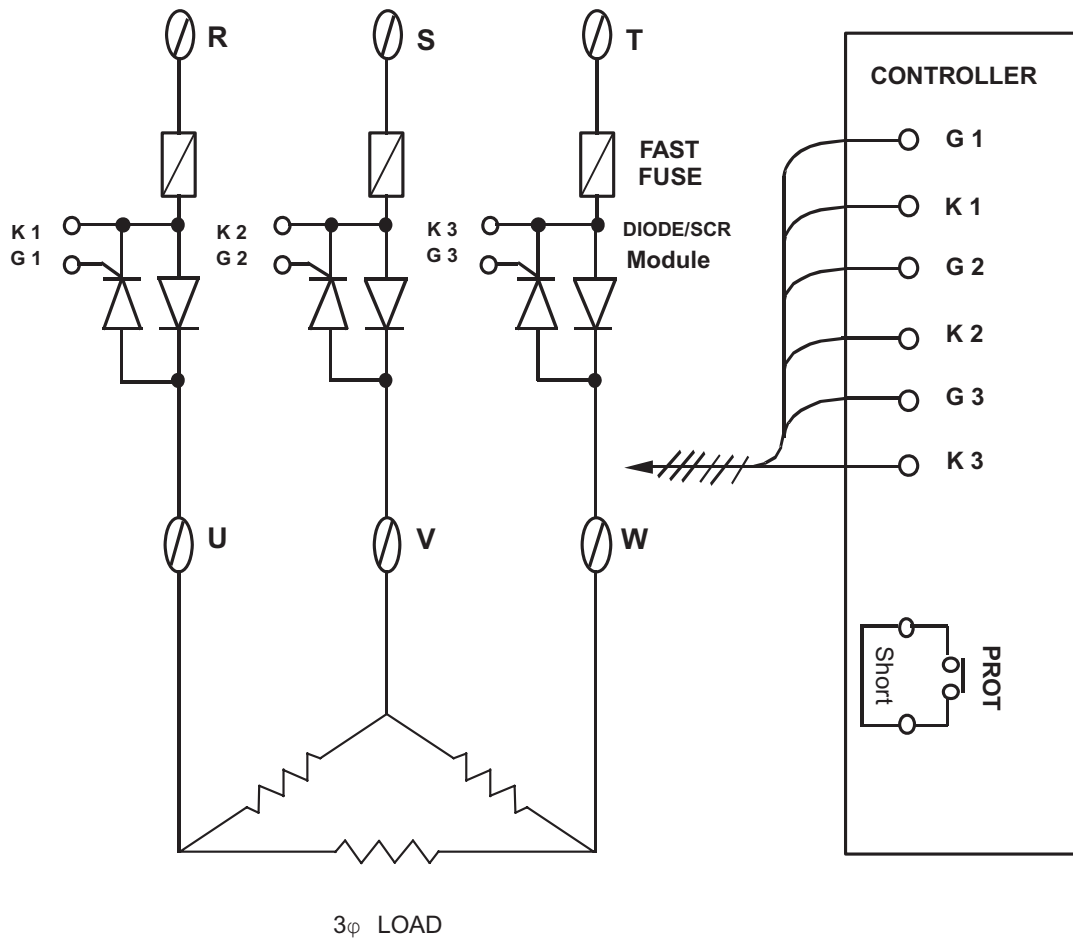

17.6 1Ø Zero crossing control (By SCR module)

△ Available Models : NC2838/NC2838P, NC2738/NC2738P
NC2438/NC2438P

△ OUT1: 1Ø SCR zero cross control

△ Parameter setting : OUTY=0
CYT1=1

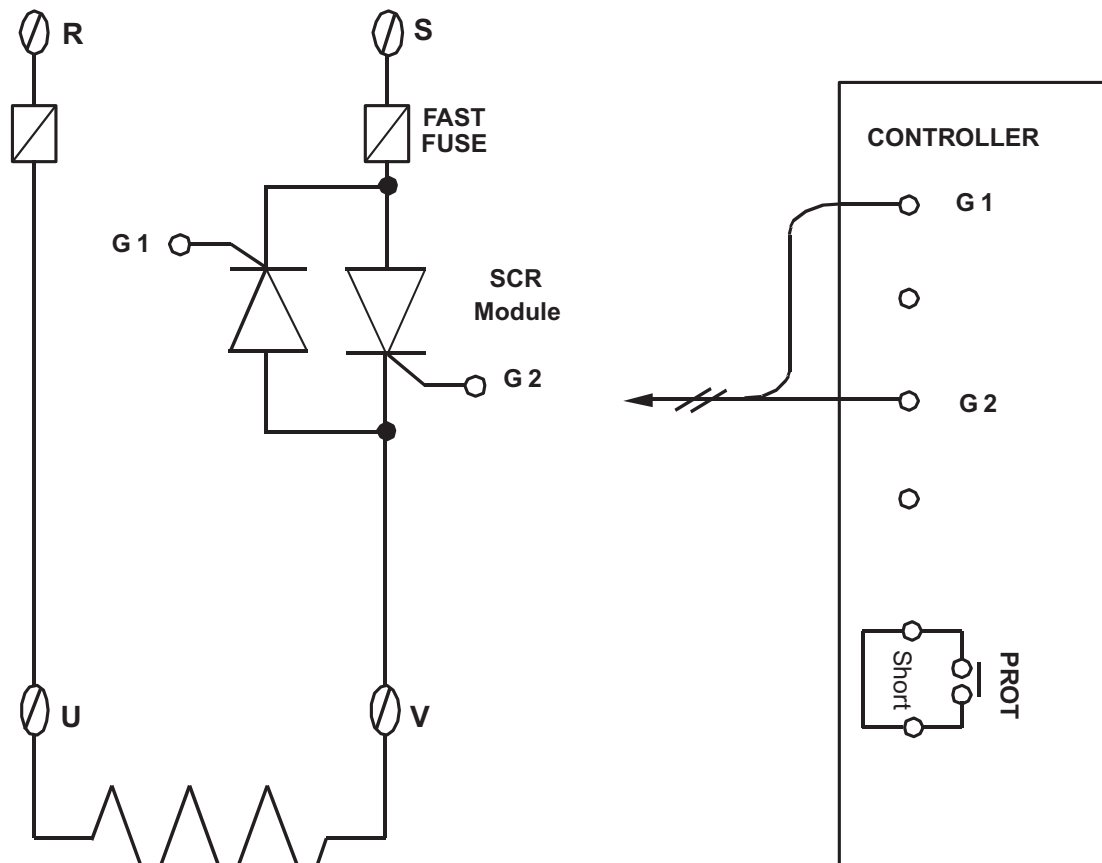

TIME CHART:

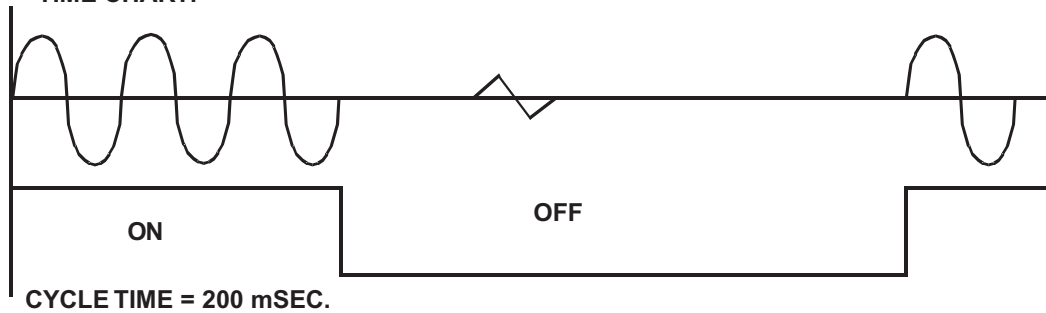

17.7 1Ø Zero crossing control (By TRIAC)

△ Available Models : NC2838/NC2838P, NC2738/2738P
NC2438/2438P

△ OUT1: 1Ø SCR zero cross control

△ Data Change : OUTY=0
CYT1=1

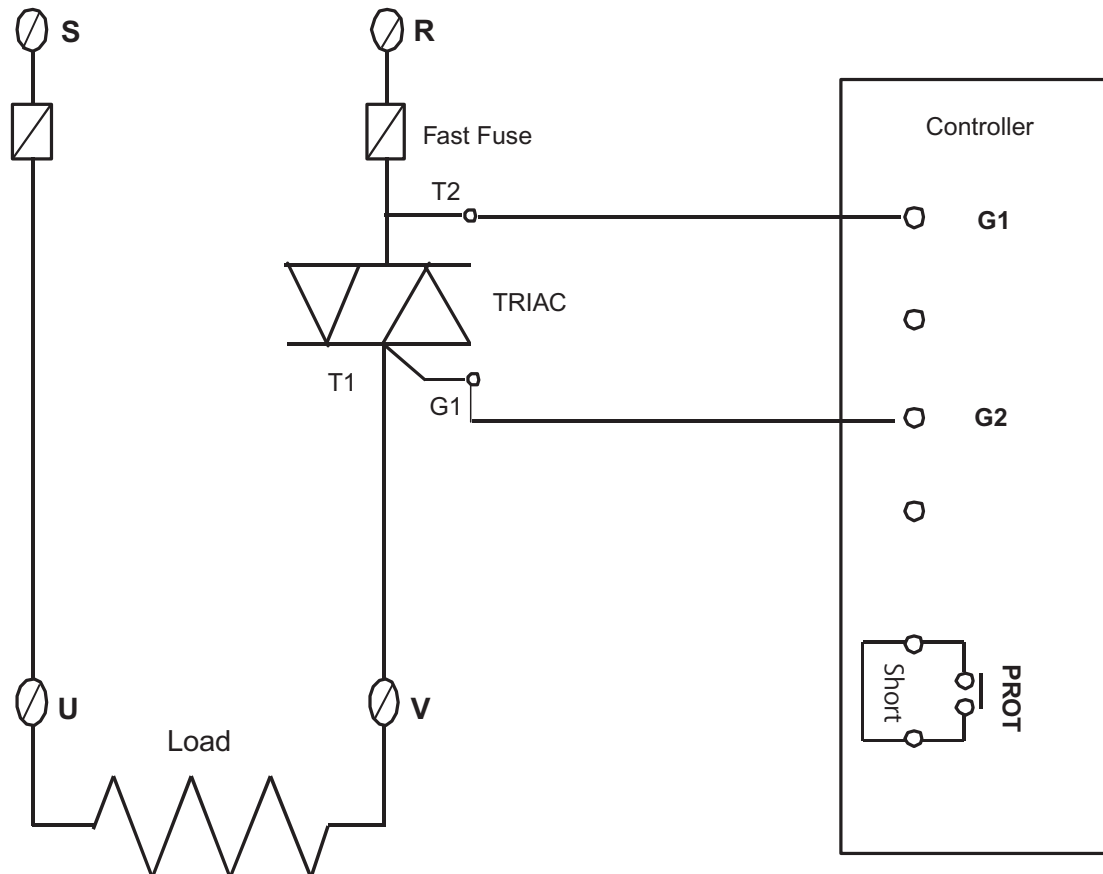

17.8 3Ø Zero crossing control (By SCR module)

△ Available Models : NC2838/NC2838P

△ OUT1: 3Ø SCR zero cross control

△ Data Change : OUTY=0
CYT1=1

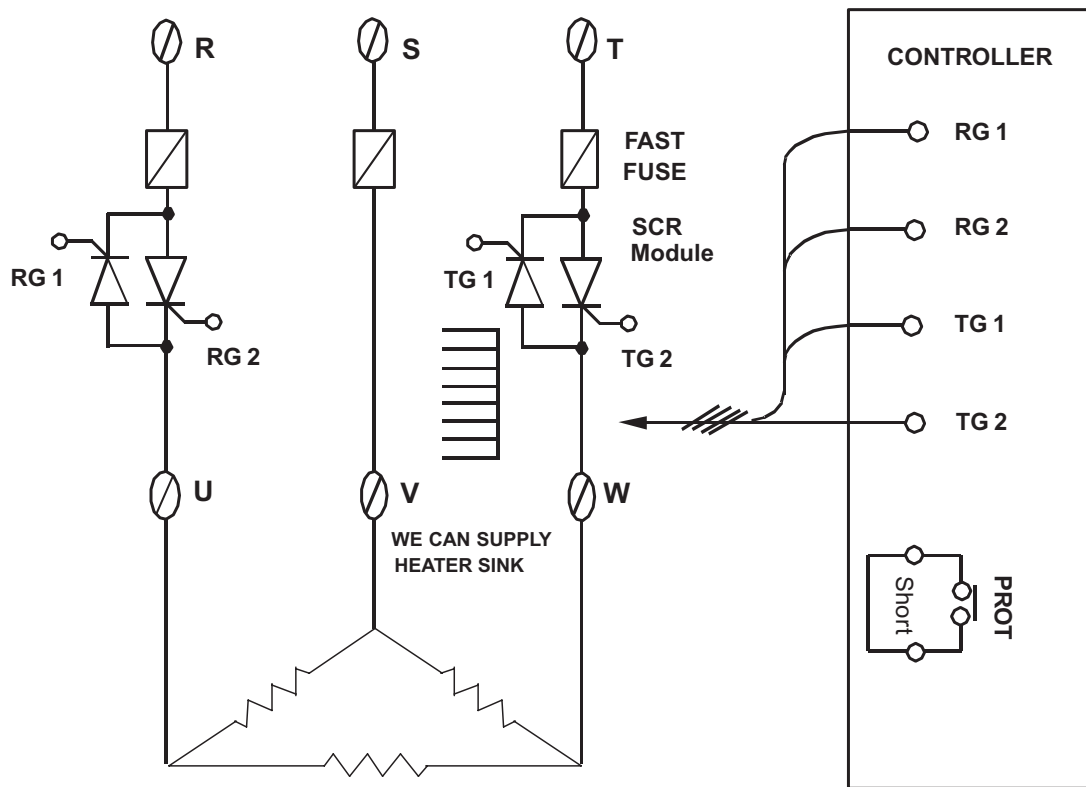

TIME CHART:

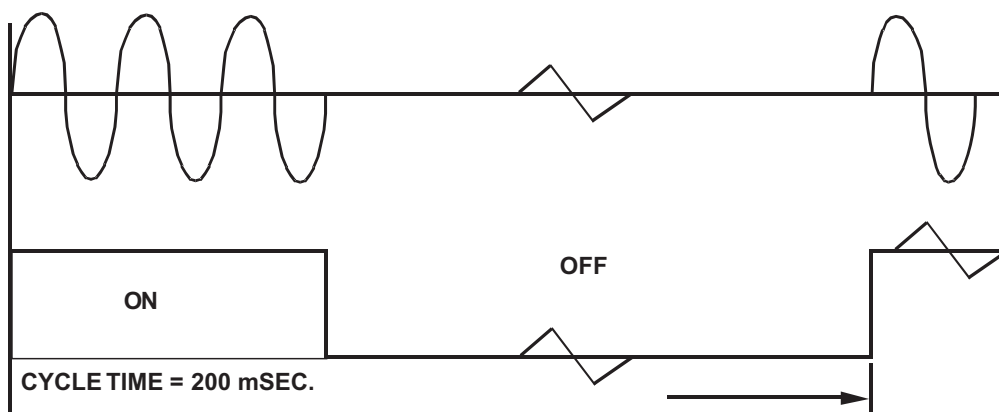

17.9 3Ø Zero crossing control (By TRIAC)

△ Available Models : NC2838/NC2838P

△ OUT1: 3Ø SCR zero cross control

△ Data Change : OUTY=0

CYT1=1

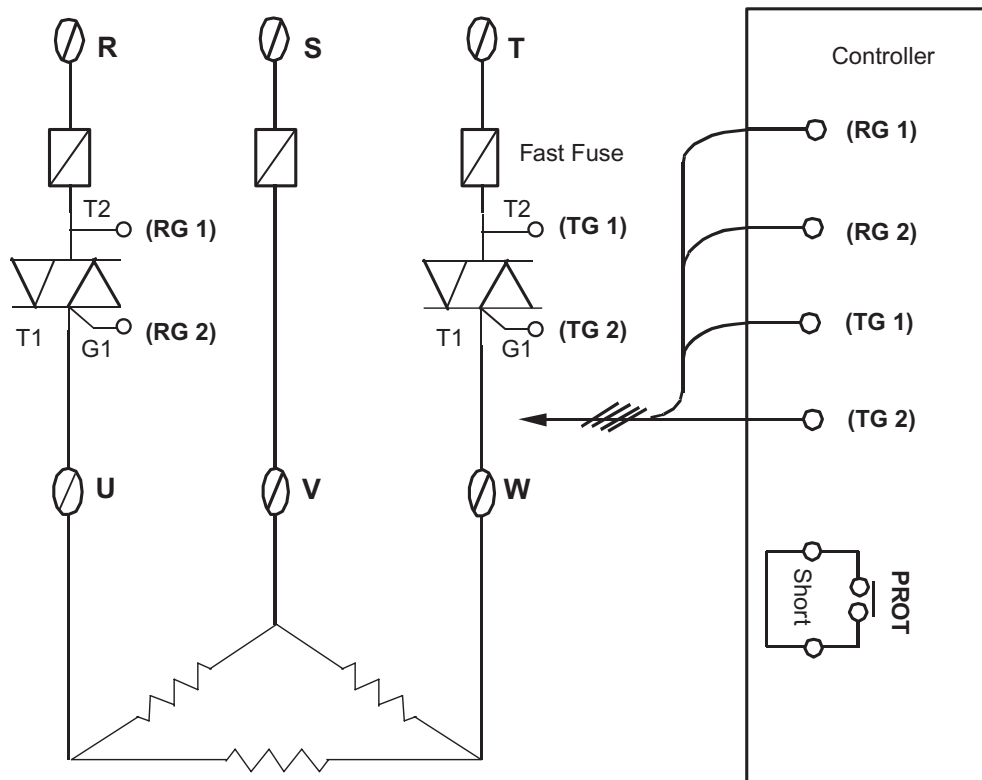

17.10 3 wires proportional motor valve control

- Δ Available Models : NC2838/NC2838P, NC2738/NC2738P
NC2538/NC2538P, NC2638/NC2638P
NC2438/NC2438P
- Δ Data Change : OUTY=3
CYT1=1 ~ 100sec.
(Manufacturing default setting "5" seconds.)
RUCY=5 ~ 200 seconds.
1. CYT1 is the cycle time of Open / Close
 2. RUCY is the 0 ~ 100% running time of motor valve

MOTOR VALVE

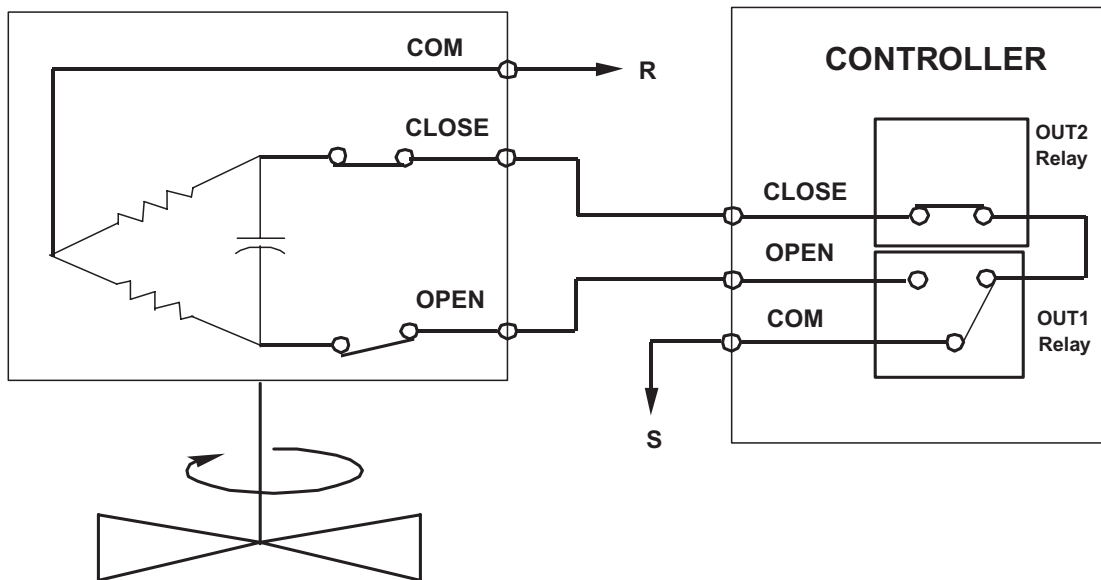

17.11 Wiring diagram of PC communication

RS232 Connection Diagram

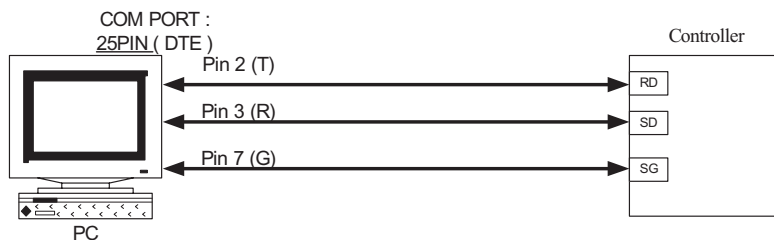
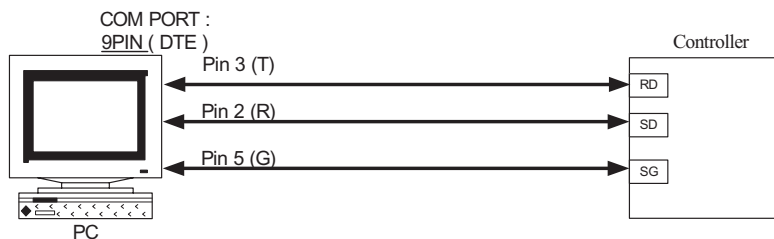

NOTE:

- 1.The length of cable be connected between controller and PC should not exceed 15 meter.
- 2.One Com Port can only be connected to one controller.
If more than one controller is connected to one Com Pprt communication will be failed.
- 3.Ensure that the controller's IDNO and BAUD settings are the same with PC software's settings.
- 4.For the software communication format please refer to communication manual.

RS485 Connection Diagram

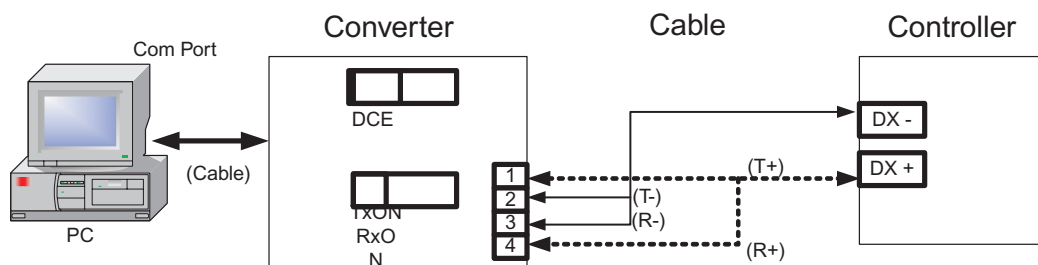

NOTE:

- 1.The length of cable be connected between Converter and Controller can't exceed 1.2 KM.
Suggestion: use "Shielded Cable".
- 2.One Com Port can be connected up to a maximum of 30 Controllers.
- 3.Ensure that the Controller's IDNO and BAUD settings are the same with PC software's settings.
- 4.For the software communication format ,please refer to communication manual.